

## NPR 45/55-155



### WEIGHT RATINGS

<b>GVM</b>	4,500 kg / 5,500 kg
<b>GCM</b>	9,000 kg
<b>TOWING CAPACITY (AT 4,500KG GVM RATING)</b>	4,500 kg*

### ENGINE

<b>POWER</b>	114 kW @ 2,600 rpm
<b>TORQUE</b>	419 Nm @ 1,600 - 2,600 rpm

### TRANSMISSION

6 speed manual transmission (MT)
6 speed automated manual transmission (AMT)

\* Refer to back page for detailed weight rating information

ISUZU CARE	
<b>WARRANTY</b>	6 Year Standard Warranty 250,000 km / Unlimited Hours
<b>ROADSIDE ASSIST</b>	6 Year Roadside Support 24/7 Unlimited km

Subject to the conditions outlined in the IAL New Vehicle Warranty. For further information please visit [isuzu.com.au](http://isuzu.com.au) or contact your local dealer.

SERVICE AGREEMENTS			
Optional Service Packages	ESSENTIALS	ESSENTIALS PLUS	TOTAL
<b>SCHEDULED SERVICINGS</b>	●	●	●
<b>CONSUMABLES</b>		●	●
<b>ENGINE, TRANSMISSION &amp; DRIVELINE</b>			●
<b>EXTRAS</b>	After-hours Servicing, Glass, Fuel Card, Pickup - Dropoff		



INTELLIGENT SAFETY		
<b>ACTIVE SAFETY ADVANCED DRIVER ASSISTANCE SYSTEMS (ADAS)</b>	Advanced Emergency Braking	<b>(AEB)</b>
	Forward Collision Warning	<b>(FCW)</b>
	Distance Warning System	<b>(DWS)</b>
	Lane Departure Warning	<b>(LDW)</b>
	Traffic Movement Warning	<b>(TMW)</b>
	Electronic Stability Control	<b>(ESC)</b>
	Anti Skid Regulator	<b>(ASR)</b>
	Anti Lock Braking System	<b>(ABS)</b>
	Customisable Speed Limiter	<b>(CSL)</b>
	Hill Start Aid (MT only)	<b>(HSA)</b>
<b>PASSIVE SAFETY CABIN OCCUPANT SAFETY SYSTEMS (COSS)</b>	Automatic Lighting System (Front and Rear)	<b>(ALS)</b>
	Cab Tilt Warning	<b>(CTW)</b>
	Driver and front passenger airbags	
	Driver and front left hand passenger seatbelt pretensioners	
	ECE-R29 cab with side anti-intrusion beams	
Overhead shelf restraint netting		
Door mounted cornering lamps		

ENGINE	
<b>DESCRIPTION</b>	Isuzu 4HK1-TCN
<b>TYPE</b>	4 cylinder 16 valve SOHC
<b>DISPLACEMENT</b>	5,193 cc
<b>COMPRESSION RATIO</b>	17.5:1
<b>BORE X STROKE</b>	115 mm x 125 mm
<b>POWER</b>	114 kW (155PS) @ 2,600 rpm (DIN NET)
<b>TORQUE</b>	419 Nm @ 1,600 - 2,600 rpm (DIN NET)
<b>INDUCTION</b>	Electronically controlled variable nozzle turbocharger with air-to-air intercooler
<b>FUEL INJECTION</b>	Direct injection high pressure common rail
<b>EMISSION CONTROL</b>	Cooled EGR with exhaust Diesel Oxidation Catalyst (DOC). ADR 80/03 (Euro V) compliant.

Isuzu 4HK1-TCN

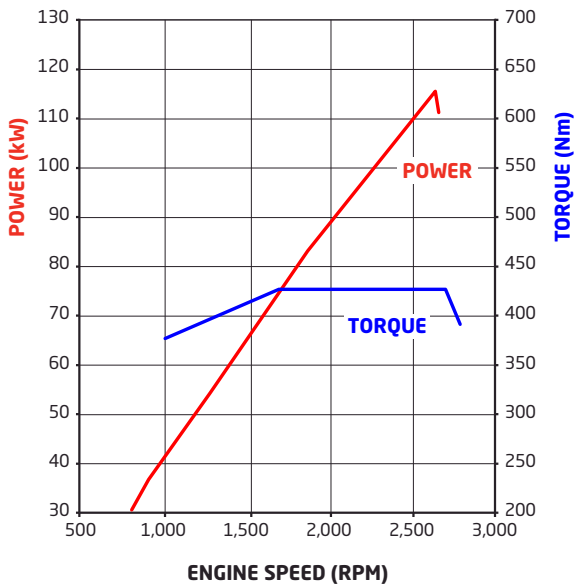

CLUTCH	
<b>MT</b>	<p><b>Type:</b> Single plate with auto adjusting hydraulic control and vacuum assistance</p> <p><b>Clutch plate diameter:</b> 325 mm</p> <p><b>Clutch lining area:</b> 966 cm<sup>2</sup></p>
<b>AMT</b>	<p><b>Type:</b> Fully automated electro/hydraulically controlled wet clutch and torque converter with lock up</p>

TRANSMISSION															
<b>MT</b>	<p><b>Description:</b> Isuzu MYY-6E</p> <p><b>Type:</b> 6 speed manual. Syncromesh on gears 1-6.</p>														
	<p><b>Ratios:</b></p> <table border="1"> <thead> <tr> <th>1ST</th> <th>2ND</th> <th>3RD</th> <th>4TH</th> <th>5TH</th> <th>6TH</th> <th>REV</th> </tr> </thead> <tbody> <tr> <td>5.979</td> <td>3.434</td> <td>2.040</td> <td>1.379</td> <td>1.000</td> <td>0.750</td> <td>5.701</td> </tr> </tbody> </table>	1ST	2ND	3RD	4TH	5TH	6TH	REV	5.979	3.434	2.040	1.379	1.000	0.750	5.701
	1ST	2ND	3RD	4TH	5TH	6TH	REV								
5.979	3.434	2.040	1.379	1.000	0.750	5.701									
<p><b>Power Take Off facility:</b> Provision on LHS of transmission case. Drive from counter gear.</p>															
<b>AMT</b>	<p><b>Description:</b> Isuzu MYY-6E</p> <p><b>Type:</b> 6 speed with both fully automatic and clutchless manual operation modes</p>														
	<p><b>Ratios:</b></p> <table border="1"> <thead> <tr> <th>1ST</th> <th>2ND</th> <th>3RD</th> <th>4TH</th> <th>5TH</th> <th>6TH</th> <th>REV</th> </tr> </thead> <tbody> <tr> <td>5.979</td> <td>3.434</td> <td>2.040</td> <td>1.379</td> <td>1.000</td> <td>0.750</td> <td>5.701</td> </tr> </tbody> </table>	1ST	2ND	3RD	4TH	5TH	6TH	REV	5.979	3.434	2.040	1.379	1.000	0.750	5.701
	1ST	2ND	3RD	4TH	5TH	6TH	REV								
5.979	3.434	2.040	1.379	1.000	0.750	5.701									
<p><b>Power Take Off facility:</b> Provision on LHS of transmission case. Drive from counter gear.</p>															

AXLES		
<b>FRONT</b>	<p><b>Description:</b> Isuzu F031</p> <p><b>Type:</b> Reverse Elliot I-beam</p> <p><b>Capacity:</b> 3,100 kg</p>	
	<b>REAR</b>	<p><b>Description:</b> Isuzu R066</p> <p><b>Type:</b> Full floating banjo with four differential pinions</p> <p><b>Capacity:</b> 6,600 kg</p> <p><b>Ratio:</b> 3.909 (MT), 4.100 (AMT)</p>

SUSPENSION	
<b>FRONT</b>	<p>Single stage alloy steel taper leaf springs</p> <p>Double acting hydraulic shock absorbers. Stabiliser bar.</p>
<b>REAR</b>	<p>Taper leaf main, taper leaf helper spring</p> <p>Double acting hydraulic shock absorbers. Stabiliser bar.</p>

BRAKES	
<b>TYPE</b>	Ventilated disc/disc with dual circuit hydraulic control, vacuum assistance and electronic brake force distribution (EBD)
<b>DIAMETER FRONT</b>	293 mm
<b>DIAMETER REAR</b>	293 mm
<b>PARK BRAKE</b>	190 mm diameter drum mounted on rear of transmission
<b>AUXILIARY BRAKE</b>	Vacuum controlled exhaust brake

STEERING	
<b>TYPE</b>	Power assisted recirculating ball
<b>GEAR RATIO</b>	20.9
<b>TURNS LOCK TO LOCK</b>	5.4
<b>WHEEL LOCK ANGLE</b>	43° (inside wheel) 33° (outside wheel)

WHEELS & TYRES		
<b>FRONT</b>	<p><b>Wheels:</b> 16 x 5.5J six stud steel</p> <p><b>Tyres:</b> 195/85R16 114/112L Michelin XJE4 Mix Energy Tubeless</p> <p><b>Steer axle tyre rating:</b> 2,360 kg</p>	
	<b>REAR</b>	<p><b>Wheels:</b> 16 x 5.5J five stud steel</p> <p><b>Tyres:</b> 195/85R16 114/112L Michelin XJE4 Mix Energy Tubeless</p> <p><b>Drive axle tyre rating:</b> 4,480 kg</p>
		<b>SPARE</b>

CHASSIS FRAME	
<b>TYPE</b>	Cold rivetted ladder frame. SAPH440 steel sidemembers. Parallel side rails and rivetless top flange.
<b>DIMENSIONS</b>	<p><b>Side rail (mm):</b> 216 x 70 x 6.0</p> <p><b>Rear frame width (mm):</b> 850</p>

FUEL TANK	
<b>TYPE</b>	Frame mounted steel fuel tank
<b>CAPACITY</b>	100L
<b>FUEL CAP</b>	Lockable

ELECTRICAL SYSTEM	
<b>TYPE</b>	24 volt
<b>ALTERNATOR</b>	90 amp
<b>STARTER MOTOR</b>	4.0 kW
<b>BATTERY</b>	2 x 80D26L (630 CCA) batteries connected in series

CABIN GENERAL FEATURES	
<b>ENGINE ACCESS</b>	Manual cab tilt to 45° with torsion bar assistance
<b>STEPS</b>	Heavy duty anti-slip steps
<b>DOORS</b>	90° opening internally reinforced front doors
<b>MIRRORS</b>	Heated and powered exterior main mirrors with flat glass and additional independently adjustable convex "spot" mirrors
<b>WIPERS</b>	Two speed windscreen wipers with intermittent wipe mode
<b>EXTERIOR LIGHTING</b>	Multi-reflector halogen headlamps
	Roof mounted clearance lamps
	Front foglamps
<b>AUDIBLE WARNING</b>	Reverse alarm
<b>GRILLE</b>	Chrome
<b>SECURITY</b>	Central locking with remote keyless entry and immobiliser

INSTRUMENTATION	
<b>MULTI INFORMATION DISPLAY</b>	AEB, FCW, DWS, LDW, TMW systems activation alerts
	CTW indicator
	Low engine oil level alert (activated when oil pan < 71% capacity)
	Vehicle systems status
	Low fuel level alert
	Fuel consumption information
	Service interval alerts
<b>GENERAL INSTRUMENTATION</b>	Hourmeter
	Adjustable vehicle speed warning
	Speedometer and tachometer
	Digital odometer with integrated dual tripmeters
	Engine coolant temperature and fuel level gauges

CABIN INTERIOR	
<b>SEATING</b>	Driver's bucket seat equipped with mechanical suspension and weight adjustment to 130 kg
	Passenger bench seat with 2 seat capacity
<b>SEATBELTS</b>	3-point lap sash seatbelts in all outboard seating positions. Centre seat lap belts.
<b>STEERING COLUMN</b>	Tilt/telescopic adjustable
<b>ENTRY ASSIST GRIPS</b>	Door and roof pillar mounted
<b>DOOR WINDOWS</b>	Electric control
<b>STORAGE</b>	Overhead shelf
	Twin cup holders
	Front centre console box and storage tray
	Front door pockets
<b>POWER OUTLET</b>	24V cigarette lighter
<b>AIR CONDITIONING</b>	Auto control
<b>INTERIOR LIGHTING</b>	Fluorescent lamp



MYISUZU CO-PILOT AUDIO VISUAL UNIT	
<b>SCREEN TYPE</b>	10.1" 1080p High Definition with capacitive touch
<b>OPERATING SYSTEM</b>	Android Automotive
<b>RADIO</b>	AM/FM/DAB+
<b>INTERNAL STORAGE CAPACITY</b>	32GB
<b>SMARTPHONE INTEGRATION</b>	USB 3.0 socket
	Wi-Fi connectivity
	Android Auto / Apple CarPlay compatible
	Phone storage pocket



MyISUZU CO-PILOT audio visual unit

DRIVER CONTROLS	
<b>SAFETY SYSTEMS</b>	AEB on/off, DWS on/off/sensitivity adjust, LDW on/off/sensitivity adjust, TMW on/off, ESC&ASR on/off, headlamps and ALS on/off, HSA on/off/sensitivity adjust (MT only)
<b>ENGINE</b>	Idle speed control
	Cruise control
<b>TRANSMISSION (AMT ONLY)</b>	Slow/fast gear engagement control, 1st gear start and normal/economy gear selection modes
	Gear selection control with R-N-D and sequential shift positions
<b>GENERAL CONTROLS</b>	Windscreen wipers (2 speed and intermittent modes), washers, exhaust brake, turn signals



AMT model shown

WEIGHTS (kg)							
MODELS	RATINGS*		LOADING LIMIT* (at ground)		CAB CHASSIS WEIGHT #		
	GVM	GCM	FRONT	REAR	FRONT	REAR	TOTAL
<b>NPR 45/55-155 SWB</b>	4,500/5,500	9,000**	2,360	4,480	1,725	735	2,460
<b>NPR 45/55-155 AMT SWB</b>	4,500/5,500	9,000**	2,360	4,480	1,750	755	2,505
<b>NPR 45/55-155 MWB</b>	4,500/5,500	9,000**	2,360	4,480	1,710	815	2,525
<b>NPR 45/55-155 AMT MWB</b>	4,500/5,500	9,000**	2,360	4,480	1,735	835	2,570

\* Vehicle ratings and axle weight limits are subject to government regulatory requirements and weight distribution analysis. Consult your Isuzu dealer to select the correct vehicle for your specific application.

\*\* 4,500kg maximum towing limit applies to 4,500kg GVM rated vehicle. Tag trailer weight should not exceed towing vehicle weight. Limit is subject to government regulatory requirements.

# Cab chassis only as supplied and including 10 litres of fuel.

DIMENSIONS (mm)													(m)
MODELS	WB	OAL	FOH	ROH	EA	CE	RT	ORT	CH	FFA (unladen)	RFA (unladen)	RFH (unladen)	TURNING CIRCLE kerb to kerb
<b>NPR 45/55-155 SWB</b>	2,765	5,135	1,100	1,260	2,080	3,452	1,650	2,080	2,270	640	755	795	10.2
<b>NPR 45/55-155 MWB</b>	3,365	5,985	1,100	1,510	2,680	4,302	1,650	2,080	2,270	640	750	785	12.4

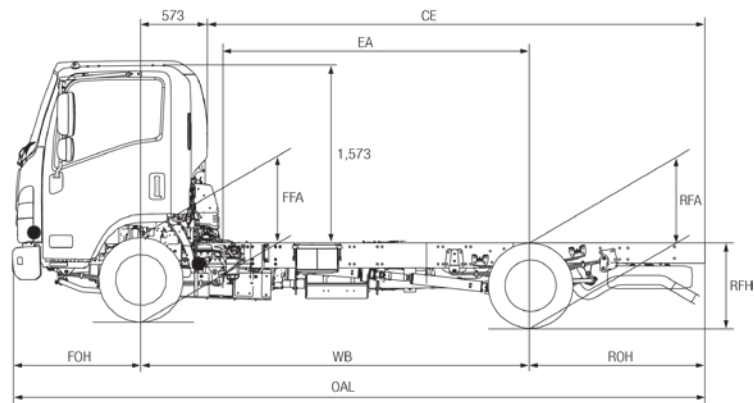
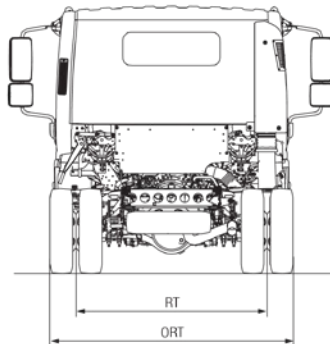
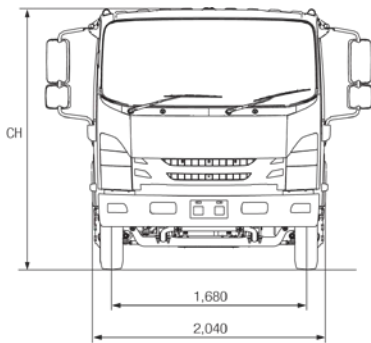

PERFORMANCE (calculated - typical paved road)				
		GEARED SPEED* (top gear at peak power engine rpm)	LOW SPEED GRADEABILITY (lowest forward gear assuming no wheel slip)	ENGINE SPEED (top gear at 100 km/h)
<b>NPR 45-155</b>	At 4,500 kg GVM	114 km/h @ 2,600 RPM	58%	2,275 rpm
<b>NPR 55-155</b>	At 5,500 kg GVM	114 km/h @ 2,600 RPM	47%	2,275 rpm

\* Maximum speed achievable depends on vehicle frontal area as well as other factors. Consult your Isuzu dealer for more detailed information.

ORDER CODES	
MODELS	CODES
<b>NPR 45/55-155 SWB</b>	NH-NPRAB-A21
<b>NPR 45/55-155 AMT SWB</b>	NH-NPRAB-Z21
<b>NPR 45/55-155 MWB</b>	NH-NPRAB-B21
<b>NPR 45/55-155 AMT MWB</b>	NH-NPRAB-D21

Subject to the conditions outlined in the IAL New Vehicle Warranty, 4x2 Isuzu N series models carry a standard factory warranty which covers the owner for the first 72 months or 250,000 kilometres (whichever comes first). All Isuzu warranties are subject to mandatory prescribed terms under Australian Consumer Law including consumer guarantees. For more details visit the Isuzu website at [www.isuzu.com.au](http://www.isuzu.com.au) which explains Isuzu warranties in more detail, or alternatively contact your local Isuzu Truck dealer. All warranties commence from date of initial delivery.

ISUZU AUSTRALIA LIMITED ABN 97 006 962 572 ("IAL"). The information in this spec sheet was correct at time of printing, but all measurements, specifications and equipment are subject to change without notice. Some equipment may have been changed and/or is available at extra cost. IAL may make changes at any time without notice, in prices, colours, materials, equipment and models. IAL makes all reasonable attempts to ensure the availability of all vehicles and equipment. The information in this spec sheet is general in nature. Your Isuzu dealer can confirm all measurements, specifications and vehicle / equipment availability upon request. To the extent permitted by the law, IAL is not liable to any person as result of reliance on the content of this spec sheet.