

NMR 60/45-150



WEIGHT RATINGS

GVM	6,000 / 4,500 kg
GCM (WITH MT)	9,500 / 8,500 kg
GCM (WITH AMT)	8,000 kg
TOWING CAPACITY	4,000 kg*

ENGINE

POWER	110 kW @ 2,800 rpm
TORQUE	375 Nm @ 1,600 - 2,800 rpm

TRANSMISSION

6 speed manual transmission (MT)
6 speed automated manual transmission (AMT)

* Refer to back page for detailed weight rating information

ISUZU CARE	
WARRANTY	6 Year Standard Warranty
	250,000 km / Unlimited Hours
ROADSIDE ASSIST	6 Year Roadside Support
	24/7 Unlimited km

Subject to the conditions outlined in the IAL New Vehicle Warranty. For further information please visit isuzu.com.au or contact your local dealer.

SERVICE AGREEMENTS			
Optional Service Packages	ESSENTIALS	ESSENTIALS PLUS	TOTAL
SCHEDULED SERVICINGS	●	●	●
CONSUMABLES		●	●
ENGINE, TRANSMISSION & DRIVELINE			●
EXTRAS	After-hours Servicing, Glass, Fuel Card, Pickup - Dropoff		

INTELLIGENT SAFETY		
ACTIVE SAFETY ADVANCED DRIVER ASSISTANCE SYSTEMS (ADAS)	Advanced Emergency Braking	(AEB)
	Forward Collision Warning	(FCW)
	Distance Warning System	(DWS)
	Lane Departure Warning	(LDW)
	Traffic Movement Warning	(TMW)
	Electronic Stability Control	(ESC)
	Anti-Skid Regulator	(ASR)
	Anti-Lock Braking System	(ABS)
	Hill Start Aid (MT model only)	(HSA)
	Automatic Lighting System (Front & Rear)	(ALS)
PASSIVE SAFETY CABIN OCCUPANT SAFETY SYSTEMS (COSS)	Cab Tilt Warning (Single cab only)	(CTW)
	Driver and front passenger airbags	
	Driver and front left hand passenger seatbelt pretensioners	
	ECE-R29 cab with side anti-intrusion beams	
	Overhead shelf restraint netting	
Door mounted cornering lamps		



ENGINE	
DESCRIPTION	Isuzu 4JJ1-TCS
TYPE	4 cylinder 16 valve with chain driven DOHC
DISPLACEMENT	2,999 cc
COMPRESSION RATIO	17.5:1
BORE X STROKE	95.4 mm x 104.9 mm
POWER	110 kW (150 PS) @ 2,800 rpm (DIN NET)
TORQUE	375 Nm @ 1,600 – 2,800 rpm (DIN NET)
INDUCTION	Electronically controlled variable nozzle turbocharger with air-to-air intercooler
FUEL INJECTION	Direct injection high pressure common rail
EMISSION CONTROL	Cooled EGR with exhaust Diesel Particulate Diffuser (DPD). ADR 80/03 (Euro V / EEV) compliant

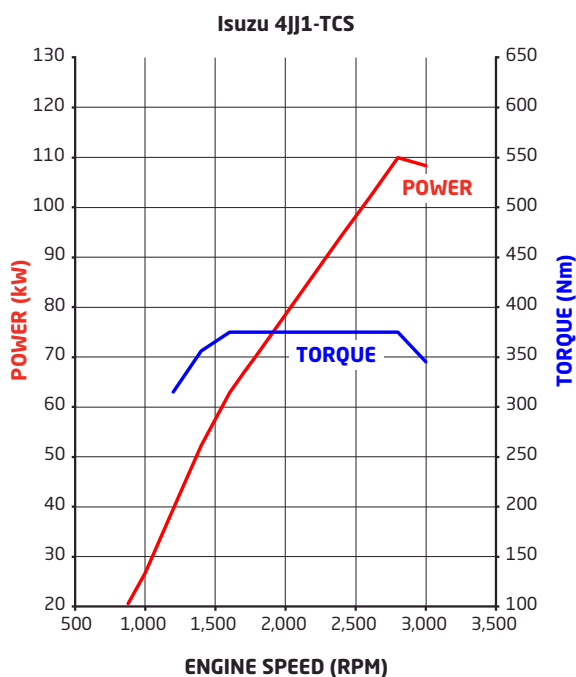

CLUTCH	
MT	Type: Single plate with auto adjusting hydraulic control and vacuum assistance Clutch Plate Diameter: 300 mm Clutch lining area: 847cm ²
AMT	Type: Fully automated electro/hydraulically controlled wet clutch and torque converter (TC) with lock up

TRANSMISSION															
MT	Description: Isuzu MYY-6E Type: 6 speed manual. Synchromesh on gears 1-6. Ratios: <table border="1"> <thead> <tr> <th>1ST</th> <th>2ND</th> <th>3RD</th> <th>4TH</th> <th>5TH</th> <th>6TH</th> <th>REV</th> </tr> </thead> <tbody> <tr> <td>5.979</td> <td>3.434</td> <td>2.04</td> <td>1.379</td> <td>1</td> <td>0.75</td> <td>5.701</td> </tr> </tbody> </table> Power Take Off facility: Provision on LHS of transmission case. Drive from counter gear.	1ST	2ND	3RD	4TH	5TH	6TH	REV	5.979	3.434	2.04	1.379	1	0.75	5.701
	1ST	2ND	3RD	4TH	5TH	6TH	REV								
	5.979	3.434	2.04	1.379	1	0.75	5.701								
Description: Isuzu MYY-6E Type: 6 speed with both fully automatic and clutchless manual operation modes Ratios: <table border="1"> <thead> <tr> <th>1ST</th> <th>2ND</th> <th>3RD</th> <th>4TH</th> <th>5TH</th> <th>6TH</th> <th>REV</th> </tr> </thead> <tbody> <tr> <td>5.979</td> <td>3.434</td> <td>2.04</td> <td>1.379</td> <td>1</td> <td>0.75</td> <td>5.701</td> </tr> </tbody> </table> Power Take Off facility: Provision on LHS of transmission case. Drive from counter gear.	1ST	2ND	3RD	4TH	5TH	6TH	REV	5.979	3.434	2.04	1.379	1	0.75	5.701	
1ST	2ND	3RD	4TH	5TH	6TH	REV									
5.979	3.434	2.04	1.379	1	0.75	5.701									
AMT	Description: Isuzu MYY-6E Type: 6 speed with both fully automatic and clutchless manual operation modes Ratios: <table border="1"> <thead> <tr> <th>1ST</th> <th>2ND</th> <th>3RD</th> <th>4TH</th> <th>5TH</th> <th>6TH</th> <th>REV</th> </tr> </thead> <tbody> <tr> <td>5.979</td> <td>3.434</td> <td>2.04</td> <td>1.379</td> <td>1</td> <td>0.75</td> <td>5.701</td> </tr> </tbody> </table> Power Take Off facility: Provision on LHS of transmission case. Drive from counter gear.	1ST	2ND	3RD	4TH	5TH	6TH	REV	5.979	3.434	2.04	1.379	1	0.75	5.701
1ST	2ND	3RD	4TH	5TH	6TH	REV									
5.979	3.434	2.04	1.379	1	0.75	5.701									

AXLES		
FRONT	Description: Isuzu F1026 Type: Independent wishbone Capacity: 2600 kg	
	REAR	Description: Isuzu R050 Type: Full floating banjo with four differential pinions Capacity: 5,000 kg Ratio: 4.777 (MT), 4.300 (AMT)

SUSPENSION	
FRONT	Coil springs Double acting hydraulic shock absorbers
REAR	Taper leaf main, taper leaf helper spring Double acting hydraulic shock absorbers

BRAKES	
TYPE	Ventilated disc/disc with dual circuit hydraulic control, vacuum assistance and electronic brake force distribution (EBD)
DIAMETER FRONT	293 mm
DIAMETER REAR	293 mm
PARK BRAKE	190 mm diameter drum mounted on rear of transmission
AUXILIARY BRAKE	Vacuum controlled exhaust brake

STEERING	
TYPE	Power assisted rack and pinion
TURNS LOCK TO LOCK	4.2
WHEEL LOCK ANGLE	38.00° (inside wheel) 35.75° (outside wheel)

WHEELS & TYRES		
FRONT	Wheels: 16 x 5.5J five stud steel Tyres: 205 / 85R16 117 / 115L Michelin XJE4 Mix Energy Tubeless Steer axle tyre rating: 2,570 kg	
	REAR	Wheels: 16 x 5.5J five stud steel Tyres: 205 / 85R16 117 / 115L Michelin XJE4 Mix Energy Tubeless Drive axle tyre rating: 4,860 kg
		SPARE

CHASSIS FRAME	
TYPE	Cold rivetted ladder frame. SAPH440 steel sidemembers.
DIMENSIONS	Side rail (mm): 180 x 65 x 4.0 Rear frame width (mm): 700

FUEL TANK	
TYPE	Frame mounted steel fuel tank
CAPACITY	75L (SWB), 100L (MWB)
FUEL CAP	Lockable

ELECTRICAL SYSTEM	
TYPE	24 volt
ALTERNATOR	90 amp
STARTER MOTOR	4.0 kW
BATTERY	2 x 80D26L (630 CCA) batteries connected in series

CABIN GENERAL FEATURES	
ENGINE ACCESS	Manual cab tilt to 45° with torsion bar assistance
STEPS	Heavy duty anti-slip steps
DOORS	90° opening internally reinforced front doors
MIRRORS	Heated and powered exterior main mirrors with flat glass and additional independantly adjustable convex "spot" mirrors
WIPERS	Two speed windscreen wipers with intermittent wipe mode
EXTERIOR LIGHTING	Multi-reflector halogen headlamps
AUDIBLE WARNING	Reverse alarm
GRILLE	Body coloured
SECURITY	Central locking with remote keyless entry and immobiliser

INSTRUMENTATION	
MULTI INFORMATION DISPLAY	AEB, FCW, DWS, LDW, TMW systems activation alerts
	CTW indicator
	Vehicle systems status
	Low fuel level alert
	Fuel consumption information
	Service interval alerts
GENERAL INSTRUMENTATION	Hourmeter
	Adjustable vehicle speed warning
	Speedometer and tachometer
	Digital odometer with integrated dual tripmeters
	Engine coolant temperature and fuel level guages

CABIN INTERIOR	
SEATING	Driver's bucket seat equipped with mechanical suspension and weight adjustment to 130kg
	Passenger bench seat with 2 seat capacity
SEATBELTS	3-point lap sash seatbelts in all outboard seating positions. Centre seat lap belts.
STEERING COLUMN	Tilt/telescopic adjustable
ENTRY ASSIST GRIPS	Door and roof pillar mounted
DOOR WINDOWS	Electric control
STORAGE	Overhead shelf
	Twin cup holders
	Front door pockets
POWER OUTLET	24V cigarette lighter
AIRCONDITIONING	Manual control
INTERIOR LIGHTING	Flourescent lamp

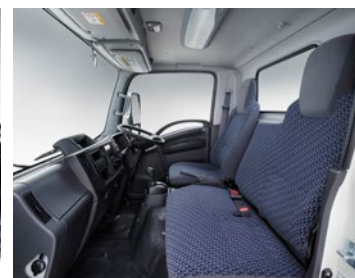
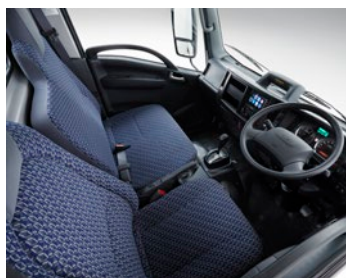

MYISUZU CO-PILOT AUDIO VISUAL UNIT	
SCREEN TYPE	10.1" 1080p High Definition with capacitive touch
OPERATING SYSTEM	Android Automotive
RADIO	AM/FM/DAB+
INTERNAL STORAGE CAPACITY	32GB
SMARTPHONE INTEGRATION	USB 3.0 socket
	Wi-Fi connectivity
	Android Auto / Apple CarPlay compatible
	Phone storage pocket



MyISUZU CO-PILOT audio visual unit

DRIVER CONTROLS	
SAFETY SYSTEMS	AEB on/off, DWS on/off/sensitivity adjust, LDW on/off/sensitivity adjust, TMW on/off, ESC&ASR on/off, headlamps and ALS on/off, HSA on/off/sensitivity adjust (MT only)
ENGINE	Idle speed control
	Cruise control
	DPD manual regeneration switch
TRANSMISSION (AMT ONLY)	Slow/fast gear engagement control, 1st gear start and normal/economy gear selection modes
	Gear selection control with P-R-N-D and sequential shift positions
GENERAL CONTROLS	Windscreen wipers (2 speed and intermittent modes), washers, exhaust brake, turn signals



AMT model shown

WEIGHTS (kg)							
MODELS	RATINGS*		LOADING LIMIT* (at ground)		CAB CHASSIS WEIGHT #		
	GVM	GCM	FRONT	REAR	FRONT	REAR	TOTAL
NMR 60/45-150 SWB	6,000/4,500	9,500/8,500**	2,570	4,860	1,495	650	2,145
NMR 60/45-150 AMT SWB	6,000/4,500	8,000**	2,570	4,860	1,515	675	2,190
NMR 60/45-150 AMT MWB	6,000/4,500	8,000**	2,570	4,860	1,495	715	2,210

* Vehicle ratings and axle weight limits are subject to government regulatory requirements and weight distribution analysis. Consult your Isuzu dealer to select the correct vehicle for your specific application.

**4,000kg maximum towing limit applies to 4,500kg GVM rated vehicle. Tag trailer weight should not exceed towing vehicle weight. Limit is subject to government regulatory requirements.

Cab chassis only as supplied and including 10 litres of fuel.

DIMENSIONS (mm)													(m)
MODELS	WB	OAL	FOH	ROH	EA	CE	RT	ORT	CH	FFA (unladen)	RFA (unladen)	RFH (unladen)	TURNING CIRCLE kerb to kerb
NMR 60/45-150 SWB	2,490	4,735	1,100	1,145	1,805	3,172	1,425	1,860	2,170	645	725	760	8.5
NMR 60/45-150 MWB	3,350	6,025	1,100	1,575	2,665	4,462	1,425	1,860	2,170	635	715	755	11.5

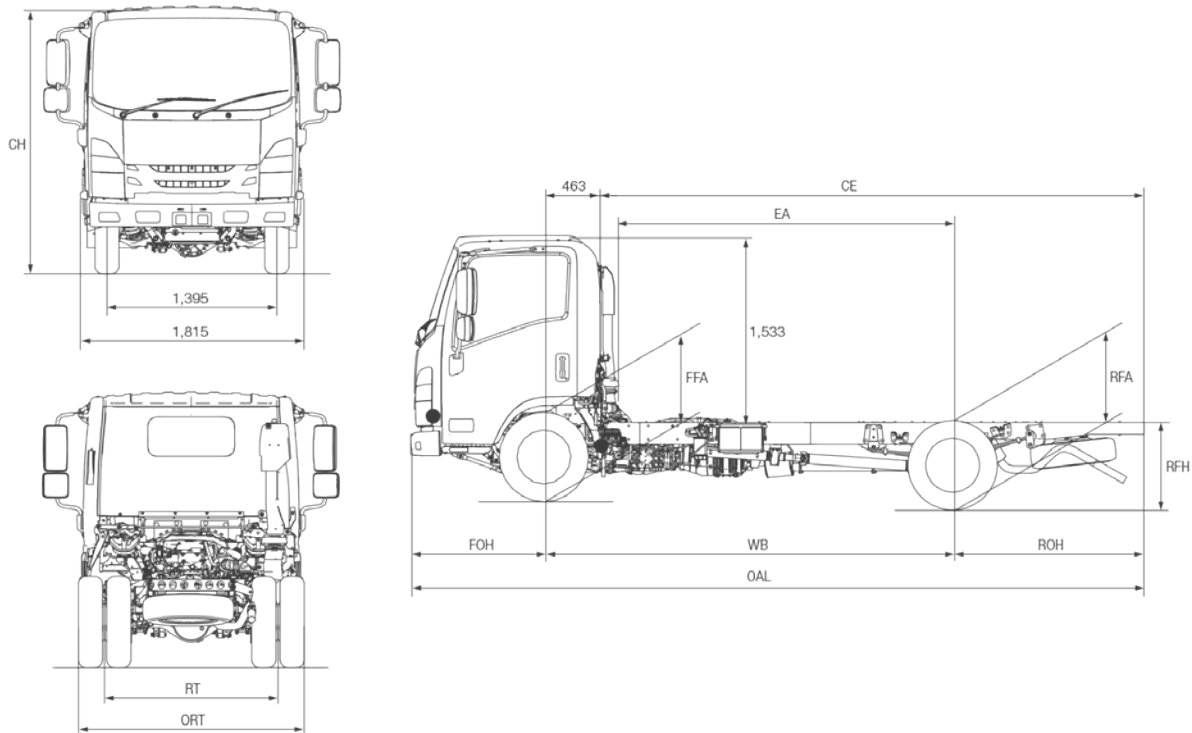

PERFORMANCE (calculated - typical paved road)				
MODELS	GVM	GEARED SPEED* (top gear at peak power engine rpm)	LOW SPEED GRADEABILITY (lowest forward gear assuming no wheel slip)	ENGINE SPEED (top gear at 100 km/h)
NMR 45-150	At 4,500 kg GVM	108 km/h @ 2,800 rpm	60%	2,595 rpm
NMR 60-150	At 6,000 kg GVM	108 km/h @ 2,800 rpm	44%	2,595 rpm
NMR 45-150 AMT	At 4,500 kg GVM	120 km/h @ 2,800 rpm	53%	2,340 rpm
NMR 60-150 AMT	At 6,000 kg GVM	120 km/h @ 2,800 rpm	40%	2,340 rpm

* Maximum speed achievable depends on vehicle frontal area as well as other factors. Consult your Isuzu dealer for more detailed information.

ORDER CODES	
MODELS	CODES
NMR 60/45-150 SWB	NH-NMRAA-F21
NMR 60/45-150 AMT SWB	NH-NMRAA-X21
NMR 60/45-150 AMT MWB	NH-NMRAA-Z21

Subject to the conditions outlined in the IAL New Vehicle Warranty, 4x2 Isuzu N series models carry a standard factory warranty which covers the owner for the first 72 months or 250,000 kilometres (whichever comes first). All Isuzu warranties are subject to mandatory prescribed terms under Australian Consumer Law including consumer guarantees. For more details visit the Isuzu website at www.isuzu.com.au which explains Isuzu warranties in more detail, or alternatively contact your local Isuzu Truck dealer. All warranties commence from date of initial delivery.

ISUZU AUSTRALIA LIMITED ABN 97 006 962 572 ("IAL"). The information in this spec sheet was correct at time of printing, but all measurements, specifications and equipment are subject to change without notice. Some equipment may have been changed and/or is available at extra cost. IAL may make changes at any time without notice, in prices, colours, materials, equipment and models. IAL makes all reasonable attempts to ensure the availability of all vehicles and equipment. The information in this spec sheet is general in nature. Your Isuzu dealer can confirm all measurements, specifications and vehicle / equipment availability upon request. To the extent permitted by the law, IAL is not liable to any person as result of reliance on the content of this spec sheet.