

FXZ 240-350 6X4

FXV 240-350 6X4



FXV MODEL PICTURED

WEIGHT RATINGS*

GVM 24,000 kg
GCM 45,000 kg

ENGINE

POWER 257 kW @ 2,000 rpm
TORQUE 1,422 Nm @ 1,400 rpm

TRANSMISSION

9 speed manual transmission (MT)
6 speed automatic transmission (AT)

* Refer to back page for detailed weight rating information

ISUZU CARE	
WARRANTY	6 Year Standard Warranty
	600,000 km / 10,000 Engine Hours
ROADSIDE ASSIST	6 Year Roadside Support
	24/7 Unlimited km
HARSH APPLICATION WARRANTY (CONCRETE AGITATOR / GARBAGE COMPACTOR)	3 Year Standard Warranty
	300,000 km / no hours stipulation
	3 Year Roadside Support
	24/7 Unlimited km

INTELLIGENT SAFETY	
STANDARD FEATURES	Anti-Lock Braking System (ABS)
	Driver airbag
	Driver seatbelt pretensioner
	Low light capable reversing camera
	ECE-R29 compliant cab

SERVICE AGREEMENTS			
Optional Service Packages	ESSENTIALS	ESSENTIALS PLUS	TOTAL
SCHEDULED SERVICINGS	●	●	●
CONSUMABLES		●	●
ENGINE, TRANSMISSION & DRIVELINE			●
EXTRAS	After-hours Servicing, Glass, Fuel Card, Pickup - Dropoff		



Subject to the conditions outlined in the IAL New Vehicle Warranty. For further information please visit isuzu.com.au or contact your local dealer.

ENGINE	
DESCRIPTION	Isuzu 6UZ1-TCC
TYPE	6 cylinder 24 valve SOHC
DISPLACEMENT	9,839 cc
COMPRESSION RATIO	17.5:1
BORE X STROKE	120 mm x 145 mm
POWER	257 kW (350PS) @ 2,000 rpm (DIN NET)
TORQUE	1,422 Nm @ 1,400 rpm (DIN NET)
INDUCTION	Electronically controlled variable nozzle turbocharger with air-to-air intercooler
FUEL INJECTION	Direct injection high pressure common rail
EMISSION CONTROL	Cooled EGR with exhaust Diesel Oxidation Catalyst (DOC). ADR 80/03 (Euro V) compliant.

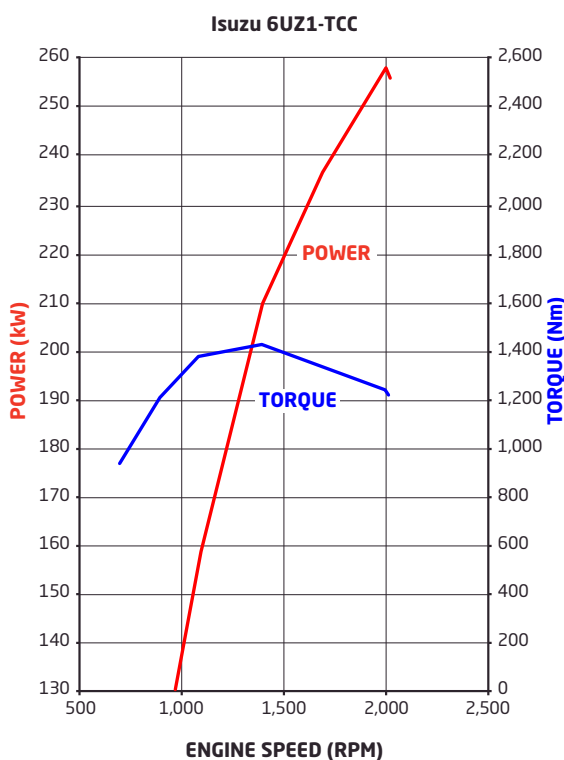

TRANSMISSION																						
MT	CLUTCH	<p>Type: Single plate with air assisted hydraulic control</p> <p>Clutch plate diameter: 432 mm</p> <p>Clutch lining area: 1,923 cm²</p>																				
	GEARBOX	<p>Description: ZF 9S 1310 TO</p> <p>Type: 9 speed with synchromesh on gears 1-8</p> <p>Ratios:</p> <table border="1"> <tr> <th>Crawler</th> <th>1st</th> <th>2nd</th> <th>3rd</th> <th>4th</th> <th>5th</th> <th>6th</th> <th>7th</th> <th>8th</th> <th>Rev</th> </tr> <tr> <td>9.48</td> <td>6.58</td> <td>4.68</td> <td>3.48</td> <td>2.62</td> <td>1.89</td> <td>1.35</td> <td>1.00</td> <td>0.75</td> <td>8.97</td> </tr> </table> <p>Power Take Off facility: Provision at rear of transmission case</p> <p>Other features: Repeat 'H' shift pattern</p>	Crawler	1st	2nd	3rd	4th	5th	6th	7th	8th	Rev	9.48	6.58	4.68	3.48	2.62	1.89	1.35	1.00	0.75	8.97
		Crawler	1st	2nd	3rd	4th	5th	6th	7th	8th	Rev											
		9.48	6.58	4.68	3.48	2.62	1.89	1.35	1.00	0.75	8.97											
		AT	<p>Description: Allison 4430</p> <p>Type: 6 speed automatic</p> <p>Ratios:</p> <table border="1"> <tr> <th>1st</th> <th>2nd</th> <th>3rd</th> <th>4th</th> <th>5th</th> <th>6th</th> <th>Rev</th> </tr> <tr> <td>4.70</td> <td>2.21</td> <td>1.53</td> <td>1.00</td> <td>0.76</td> <td>0.67</td> <td>5.55</td> </tr> </table> <p>Power Take Off facility: LHS and top openings on transmission bellhousing. Engine driven PTO drive gear.</p> <p>Other features: 6th generation electronic controls with adaptive shift. Long life TranSynd synthetic fluid.</p>	1st	2nd	3rd	4th	5th	6th	Rev	4.70	2.21	1.53	1.00	0.76	0.67	5.55					
1st	2nd		3rd	4th	5th	6th	Rev															
4.70	2.21		1.53	1.00	0.76	0.67	5.55															

AXLES	
FRONT	Description: Meritor FG941
	Type: Reverse Elliot I-beam
	Capacity: 6,600 kg
REAR	Description: Meritor MT-14X
	Type: Tandem drive
	Other features: Inter-axle lock and cross locks fitted to both axles
	Capacity: 18,100 kg
Ratio: 4.875:1 (except FXZ/FXY AUTO MLWB models), 5.286:1 (FXZ/FXY AUTO MLWB models)	

SUSPENSION		
FRONT	Type: Single stage alloy steel taper-leaf springs	
	Other features: Double acting hydraulic shock absorbers. Stabiliser bar.	
REAR	FXZ	Type: Taper leaf spring with Isuzu 6 rod and trunnion location system
	FX4	Description: Hendrickson HAS461
		Type: Airbag
Capacity: 20,865 kg at ground		

BRAKES	
DESCRIPTION	Meritor 'Q-Plus'
TYPE	Full air 'S-Cam' front and rear drum brakes
DIAMETER X WIDTH FRONT	419 x 127 mm
DIAMETER X WIDTH REAR	419 x 178 mm
PARK BRAKE	Spring park brake acting on all rear wheels
AUXILIARY BRAKE	Air controlled exhaust brake

STEERING	
TYPE	Power assisted recirculating ball
GEAR RATIO	18.5:1
TURNS LOCK TO LOCK	3.7
WHEEL LOCK ANGLE	40° (inside wheel) / 32° (outside wheel)

WHEELS & TYRES		
FRONT	WHEELS	22.5 x 8.25 ten stud ISO standard steel wheels
	TYRES	295/80R22.5 152/148M Michelin X Multi Z 2 Tubeless
	STEER AXLE TYRE RATING	7,100 kg
REAR	WHEELS	22.5 x 8.25 ten stud ISO standard steel wheels
	TYRES	11R22.5 148/145L Michelin X Multi D Tubeless
	TANDEM AXLE TYRE RATING	23,200 kg
SPARE	Rim supplied. Winch type carrier (except FXZ MLWB).	

CHASSIS FRAME	
TYPE	Cold rivetted ladder frame.
MATERIAL	HT540A steel members
DIMENSIONS	Side rail (mm): 285 x 85 x 7.0 Rear frame width (mm): 850

FUEL TANK	
TYPE	Frame mounted aluminium fuel tank
CAPACITY	400 L
FUEL CAP	Lockable

ELECTRICAL SYSTEM	
TYPE	24 volt
ALTERNATOR	90 amp
STARTER MOTOR	5.0 kW
BATTERY	2 x 115E41L (651 CCA) batteries connected in series
CAN BUS PROVISION	Underdash CAN system access plug for connection to a Fleet Management System (FMS) (not supplied)

CABIN SPECIFICATIONS & APPOINTMENTS

CABIN GENERAL FEATURES	
ENGINE ACCESS	Electro-hydraulic cab tilt
CAB MOUNTING	Rear coil spring suspension with hydraulic shock absorbers
STEPS	Heavy duty anti-slip steps
DOORS	90° opening internally reinforced front doors
MIRRORS	Heated and powered exterior main mirrors with flat glass and additional independently adjustable convex "spot" mirrors
WIPERS	Two speed windscreen wipers with intermittent wipe mode
EXTERIOR LIGHTING	LED main beam and halogen high beam headlamps. Chrome surround.
	Roof mounted clearance lamps
	Front foglamps
AUDIBLE WARNING	Reverse alarm
GRILLE	Chrome
FRONT BUMPER	Body coloured air dam type
SECURITY	Central locking with remote keyless entry and immobiliser

CABIN INTERIOR	
SEATING	Isri 6860/875 NTS air suspension driver's seat
	Front passenger adjustable bucket seat and front centre seat with folding seat back
SEATBELTS	3-point lap sash seatbelts in all outboard seating positions. Driver seatbelt integrated with driver seat. Centre seat lap belts.
STEERING COLUMN	Tilt/telescopic adjustable
ENTRY ASSIST GRIPS	Door and roof pillar mounted
DOOR WINDOWS	Electric control
STORAGE	Overhead compartments
	Twin cup holders
	Centre console box and storage tray
	Passenger glovebox
	Door pockets
POWER OUTLET	24V cigarette lighter
	2.4A high current fast charge USB socket
AIRCONDITIONING	Auto control
INTERIOR LIGHTING	Fluorescent lamp
REAR COMPARTMENT	ADR 42 compliant sleeper with mattress

MYISUZU CO-PILOT AUDIO VISUAL UNIT	
SCREEN TYPE	10.1" 1080p High Definition with capacitive touch
OPERATING SYSTEM	Android Automotive
RADIO	AM/FM/DAB+
INTERNAL STORAGE CAPACITY	32GB
SMARTPHONE INTEGRATION	USB 3.0 socket
	Wi-Fi connectivity
	Android Auto / Apple CarPlay compatible
	Phone storage pocket with wireless charging facility

DRIVER CONTROLS	
ENGINE	Idle speed control
	Cruise control
TRANSMISSION (AT ONLY)	Push button gear selection control
GENERAL CONTROLS	Headlamp on/off and levelling, windscreen wipers (2 speed and intermittent modes), washers, exhaust brake, turn signals
	Inter-axle lock and cross lock engage switches

INSTRUMENTATION	
MULTI INFORMATION DISPLAY	Vehicle systems status
	Low fuel level alert
	Fuel consumption information
	Service interval alerts
	Hourmeter
GENERAL INSTRUMENTATION	Adjustable vehicle speed warning
	Speedometer and tachometer
	Digital odometer with integrated dual tripmeters
	Transmission oil level, oil life, filter life, and condition monitor display (AT only)
	Engine coolant temperature, fuel level and air pressure gauges



FX2 240-350 6X4 FXY 240-350 6X4

WEIGHTS (kg)							
MODELS	RATINGS*		LOADING LIMIT* (at ground)		CAB CHASSIS WEIGHT #		
	GVM	GCM	FRONT	REAR	FRONT	REAR	TOTAL
FXZ 240-350 AUTO MLWB	24,000	45,000	6,600	18,100	4,120	3,340	7,460
FXZ 240-350 LWB	24,000	45,000	6,600	18,100	3,945	3,540	7,485
FXZ 240-350 AUTO LWB	24,000	45,000	6,600	18,100	4,130	3,575	7,705
FXY 240-350 AUTO MLWB	24,000	45,000	6,600	18,100	4,075	3,130	7,205
FXY 240-350 LWB	24,000	45,000	6,600	18,100	3,925	3,320	7,245
FXY 240-350 AUTO LWB	24,000	45,000	6,600	18,100	4,105	3,350	7,455

* Vehicle ratings and front/rear weight limits are subject to government regulatory requirements and weight distribution analysis. Consult your Isuzu dealer to select the correct vehicle for your specific application.

Cab chassis only as supplied and including 10 litres of fuel.

DIMENSIONS (mm)													(m)
MODELS	WB	OAL	FOH	ROH	EA	CE	RT	ORT	CH	FFA (unladen)	RFA (unladen)	RFH (unladen)	TURNING CIRCLE kerb to kerb
FXZ 240-350 AUTO MLWB	4,540	8,000	1,480	1,980	3,860	5,939	1,840	2,450	2,990	920	1,095	1,140	17.1
FXZ 240-350 LWB / AUTO LWB	6,010	10,990	1,480	3,500	5,330	8,950	1,840	2,445	2,990	920	1,100	1,140	22.7
FXY 240-350 AUTO MLWB	4,540	8,000	1,480	1,980	3,860	5,939	1,840	2,450	2,990	920	1,050	1,070	17.1
FXY 240-350 LWB / AUTO LWB	6,010	10,990	1,480	3,500	5,330	8,950	1,840	2,445	2,990	920	1,040	1,065	22.7

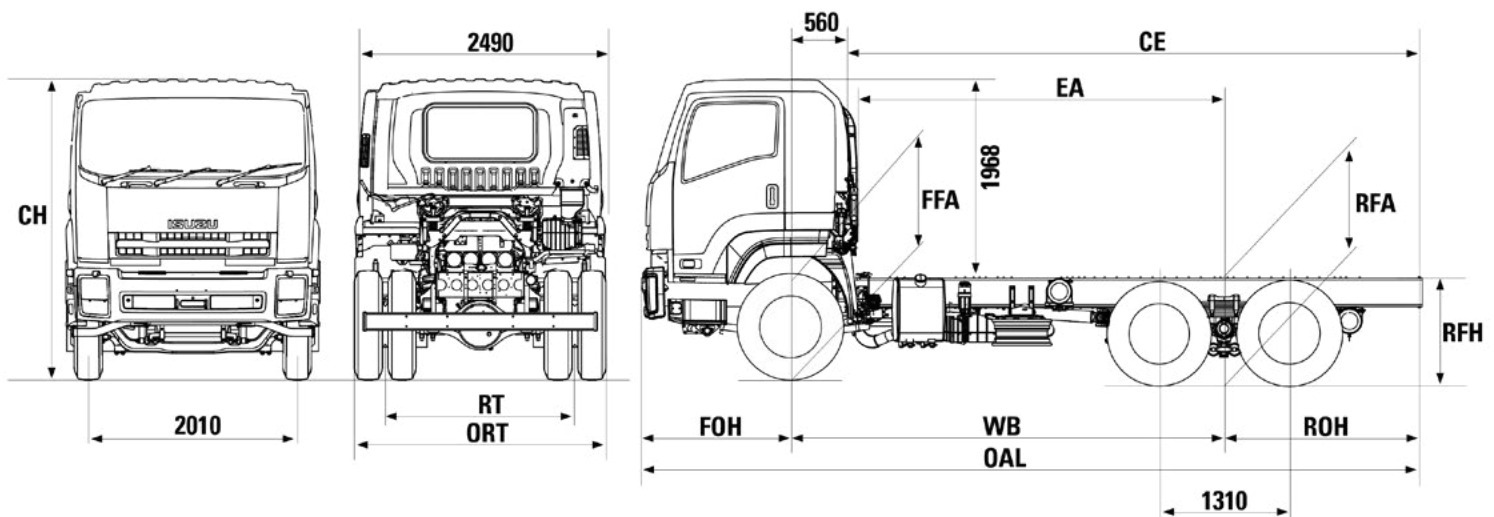

PERFORMANCE (calculated - typical paved road)				
		GEARED SPEED [^] (top gear at peak power engine rpm)	LOW SPEED GRADEABILITY (lowest forward gear assuming no wheel slip)	ENGINE SPEED (top gear at 100 km/h)
FXZ/FXY 240-350 LWB	At 24,000 kg GVM	106 km/h @ 2,000 rpm	48%	1,890 rpm
FXZ/FXY 240-350 AUTO MLWB	At 24,000 kg GVM	109 km/h @ 2,000 rpm	60%	1,830 rpm
FXZ/FXY 240-350 AUTO LWB	At 24,000 kg GVM	119 km/h @ 2,000 rpm	55%	1,690 rpm

[^] Maximum speed achievable depends on vehicle frontal area as well as other factors. Consult your Isuzu dealer for more detailed information. Vehicle is speed limited to 100km/h.

ORDER CODES	
MODELS	CODES
FXZ 240-350 AUTO MLWB	FH-FXZJJ-L23
FXZ 240-350 LWB	FH-FXZJJ-D22
FXZ 240-350 AUTO LWB	FH-FXZJJ-N23
FXY 240-350 AUTO MLWB	FH-FXYJJ-L23
FXY 240-350 LWB	FH-FXYJJ-D22
FXY 240-350 AUTO LWB	FH-FXYJJ-N23

Subject to the conditions outlined in the IAL New Vehicle Warranty, Isuzu FX series models carry a standard factory warranty which covers the owner for the first 72 months or 600,000 kilometres or 10,000 Engine Hours (whichever comes first). All Isuzu warranties are subject to mandatory prescribed terms under Australian Consumer Law including consumer guarantees. Harsh Conditions variations to standard factory warranty may apply. For more details visit the Isuzu website at www.isuzu.com.au which explains Isuzu warranties in more detail, or alternatively contact your local Isuzu Truck dealer. All warranties commence from date of initial delivery.

ISUZU AUSTRALIA LIMITED ABN 97 006 962 572 ("IAL"). The information in this spec sheet was correct at time of printing, but all measurements, specifications and equipment are subject to change without notice. Some equipment may have been changed and/or is available at extra cost. IAL may make changes at any time without notice, in prices, colours, materials, equipment and models. IAL makes all reasonable attempts to ensure the availability of all vehicles and equipment. The information in this spec sheet is general in nature. Your Isuzu dealer can confirm all measurements, specifications and vehicle / equipment availability upon request. To the extent permitted by the law, IAL is not liable to any person as result of reliance on the content of this spec sheet.