

## FXR 165-350 4X2 FXD 165-350 4X2



### WEIGHT RATINGS\*

GVM	16,500 kg
GCM	38,000 kg

### ENGINE

POWER	257 kW @ 2,000 rpm
TORQUE	1,422 Nm @ 1,400 rpm

### TRANSMISSION

9 speed manual transmission (MT)
6 speed automatic transmission (AT)

\* Refer to back page for detailed weight rating information

ISUZU CARE	
<b>WARRANTY</b>	6 Year Standard Warranty
	600,000 km / 10,000 Engine Hours
<b>ROADSIDE ASSIST</b>	6 Year Roadside Support
	24/7 Unlimited km
<b>HARSH APPLICATION WARRANTY (CONCRETE AGITATOR / GARBAGE COMPACTOR)</b>	3 Year Standard Warranty
	300,000 km / no hours stipulation
	3 Year Roadside Support
	24/7 Unlimited km

INTELLIGENT SAFETY	
<b>STANDARD FEATURES</b>	Anti-Lock Braking System (ABS)
	Driver airbag
	Driver seatbelt pretensioner
	Low light capable reversing camera
	ECE-R29 compliant cab

SERVICE AGREEMENTS			
Optional Service Packages	ESSENTIALS	ESSENTIALS PLUS	TOTAL
<b>SCHEDULED SERVICINGS</b>	●	●	●
<b>CONSUMABLES</b>		●	●
<b>ENGINE, TRANSMISSION &amp; DRIVELINE</b>			●
<b>EXTRAS</b>	After-hours Servicing, Glass, Fuel Card, Pickup - Dropoff		



Subject to the conditions outlined in the IAL New Vehicle Warranty. For further information please visit [isuzu.com.au](http://isuzu.com.au) or contact your local dealer.

ENGINE	
<b>DESCRIPTION</b>	Isuzu 6UZ1-TCC
<b>TYPE</b>	6 cylinder 24 valve SOHC
<b>DISPLACEMENT</b>	9,839 cc
<b>COMPRESSION RATIO</b>	17.5:1
<b>BORE X STROKE</b>	120 mm x 145 mm
<b>POWER</b>	257 kW (350PS) @ 2,000 rpm (DIN NET)
<b>TORQUE</b>	1,422 Nm @ 1,400 rpm (DIN NET)
<b>INDUCTION</b>	Electronically controlled variable nozzle turbocharger with air-to-air intercooler
<b>FUEL INJECTION</b>	Direct injection high pressure common rail
<b>EMISSION CONTROL</b>	Cooled EGR with exhaust Diesel Oxidation Catalyst (DOC). ADR 80/03 (Euro V) compliant.

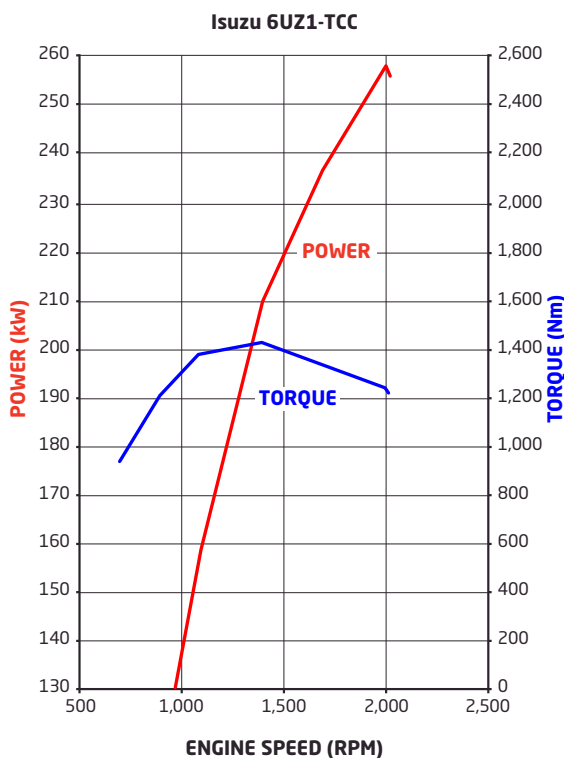

TRANSMISSION																						
<b>MT</b>	<b>CLUTCH</b>	<p><b>Type:</b> Single plate with air assisted hydraulic control</p> <p><b>Clutch plate diameter:</b> 432 mm</p> <p><b>Clutch lining area:</b> 1,923 cm<sup>2</sup></p>																				
	<b>GEARBOX</b>	<p><b>Description:</b> ZF 9S 1310 T0</p> <p><b>Type:</b> 9 speed with synchromesh on gears 1-8</p> <p><b>Ratios:</b></p> <table border="1"> <tr> <th>Crawler</th> <th>1st</th> <th>2nd</th> <th>3rd</th> <th>4th</th> <th>5th</th> <th>6th</th> <th>7th</th> <th>8th</th> <th>Rev</th> </tr> <tr> <td>9.48</td> <td>6.58</td> <td>4.68</td> <td>3.48</td> <td>2.62</td> <td>1.89</td> <td>1.35</td> <td>1.00</td> <td>0.75</td> <td>8.97</td> </tr> </table> <p><b>Power Take Off facility:</b> Provision at rear of transmission case</p> <p><b>Other features:</b> Repeat 'H' shift pattern</p>	Crawler	1st	2nd	3rd	4th	5th	6th	7th	8th	Rev	9.48	6.58	4.68	3.48	2.62	1.89	1.35	1.00	0.75	8.97
		Crawler	1st	2nd	3rd	4th	5th	6th	7th	8th	Rev											
		9.48	6.58	4.68	3.48	2.62	1.89	1.35	1.00	0.75	8.97											
		<b>Description:</b> Allison 4430																				
<b>Type:</b> 6 speed automatic																						
<b>Ratios:</b>																						
<b>AT</b>	<table border="1"> <tr> <th>1st</th> <th>2nd</th> <th>3rd</th> <th>4th</th> <th>5th</th> <th>6th</th> <th>Rev</th> </tr> <tr> <td>4.70</td> <td>2.21</td> <td>1.53</td> <td>1.00</td> <td>0.76</td> <td>0.67</td> <td>5.55</td> </tr> </table> <p><b>Power Take Off facility:</b> LHS and top openings on transmission bellhousing. Engine driven PTO drive gear.</p> <p><b>Other features:</b> 6th generation electronic controls with adaptive shift. Long life TranSynd synthetic fluid.</p>	1st	2nd	3rd	4th	5th	6th	Rev	4.70	2.21	1.53	1.00	0.76	0.67	5.55							
	1st	2nd	3rd	4th	5th	6th	Rev															
	4.70	2.21	1.53	1.00	0.76	0.67	5.55															

AXLES	
<b>FRONT</b>	<b>Description:</b> Meritor FG941
	<b>Type:</b> Reverse Elliot I-beam
	<b>Capacity:</b> 6,600 kg
<b>REAR</b>	<b>Description:</b> Meritor RS-23-161G
	<b>Type:</b> Single drive
	<b>Other features:</b> Cross locks fitted
	<b>Capacity:</b> 10,400 kg
	<b>Ratio:</b> 4.555:1 (MT), 4.888:1 (AT)

SUSPENSION		
<b>FRONT</b>		<b>Type:</b> Single stage alloy steel taper leaf springs
		<b>Other features:</b> Double acting hydraulic shock absorbers. Stabiliser bar.
<b>REAR</b>	<b>FXR</b>	<b>Type:</b> Multi leaf main spring, multi leaf helper spring
		<b>Other features:</b> Stabiliser bar
	<b>FXD</b>	<b>Description:</b> Hendrickson HAS230
		<b>Type:</b> Airbag
		<b>Capacity:</b> 10,400 kg at ground

BRAKES	
<b>DESCRIPTION</b>	Meritor 'Q-Plus'
<b>TYPE</b>	Full air 'S-Cam' front and rear drum brakes
<b>DIAMETER X WIDTH FRONT</b>	419 x 127 mm
<b>DIAMETER X WIDTH REAR</b>	419 x 178 mm
<b>PARK BRAKE</b>	Spring park brake acting on all rear wheels
<b>AUXILIARY BRAKE</b>	Air controlled exhaust brake

STEERING	
<b>TYPE</b>	Power assisted recirculating ball
<b>GEAR RATIO</b>	18.5:1
<b>TURNS LOCK TO LOCK</b>	3.7
<b>WHEEL LOCK ANGLE</b>	40° (inside wheel) / 32° (outside wheel)

WHEELS & TYRES	
<b>FRONT</b>	<b>Wheels:</b> 22.5 x 8.25 ten stud ISO standard steel wheels
	<b>Tyres:</b> 295/80R22.5 152/148M Michelin X Multi Z 2 Tubeless
	<b>Steer axle tyre rating:</b> 7,100 kg
<b>REAR</b>	<b>Wheels:</b> 22.5 x 8.25 ten stud ISO standard steel wheels
	<b>Tyres:</b> 11R22.5 148/145L Michelin X Multi D Tubeless
	<b>Drive axle tyre rating:</b> 11,600 kg
<b>SPARE</b>	Rim supplied. Winch type carrier.

CHASSIS FRAME	
<b>TYPE</b>	Cold rivetted ladder frame.
<b>MATERIAL</b>	HT540A steel members
<b>DIMENSIONS</b>	<p><b>Side rail (mm):</b> 285 x 85 x 7.0</p> <p><b>Rear frame width (mm):</b> 850</p>

FUEL TANK	
<b>TYPE</b>	Frame mounted aluminium fuel tank
<b>CAPACITY</b>	400 L
<b>FUEL CAP</b>	Lockable

ELECTRICAL SYSTEM	
<b>TYPE</b>	24 volt
<b>ALTERNATOR</b>	90 amp
<b>STARTER MOTOR</b>	5.0 kW
<b>BATTERY</b>	2 x 115E41L (651 CCA) batteries connected in series
<b>CAN BUS PROVISION</b>	Underdash CAN system access plug for connection to a Fleet Management System (FMS) (not supplied)

## CABIN SPECIFICATIONS & APPOINTMENTS

CABIN GENERAL FEATURES	
<b>ENGINE ACCESS</b>	Electro-hydraulic cab tilt
<b>CAB MOUNTING</b>	Rear coil spring suspension with hydraulic shock absorbers
<b>STEPS</b>	Heavy duty anti-slip steps
<b>DOORS</b>	90° opening internally reinforced front doors
<b>MIRRORS</b>	Heated and powered exterior main mirrors with flat glass and additional independently adjustable convex "spot" mirrors
<b>WIPERS</b>	Two speed windscreen wipers with intermittent wipe mode
<b>EXTERIOR LIGHTING</b>	LED main beam and halogen high beam headlamps. Chrome surround.
	Roof mounted clearance lamps
	Front foglamps
<b>AUDIBLE WARNING</b>	Reverse alarm
<b>GRILLE</b>	Chrome
<b>FRONT BUMPER</b>	Body coloured air dam type
<b>SECURITY</b>	Central locking with remote keyless entry and immobiliser

CABIN INTERIOR	
<b>SEATING</b>	Isri 6860/875 NTS air suspension driver's seat
	Front passenger adjustable bucket seat and front centre seat with folding seat back
<b>SEATBELTS</b>	3-point lap sash seatbelts in all outboard seating positions. Driver seatbelt integrated with driver seat. Centre seat lap belts.
<b>STEERING COLUMN</b>	Tilt/telescopic adjustable
<b>ENTRY ASSIST GRIPS</b>	Door and roof pillar mounted
<b>DOOR WINDOWS</b>	Electric control
<b>STORAGE</b>	Overhead compartments
	Twin cup holders
	Centre console box and storage tray
	Passenger glovebox
	Door pockets
<b>POWER OUTLETS</b>	24V cigarette lighter
	2.4A high current fast charge USB socket
<b>AIRCONDITIONING</b>	Auto control
<b>INTERIOR LIGHTING</b>	Fluorescent lamp
<b>REAR COMPARTMENT</b>	ADR 42 compliant sleeper with mattress

MYISUZU CO-PILOT AUDIO VISUAL UNIT	
<b>SCREEN TYPE</b>	10.1" 1080p High Definition with capacitive touch
<b>OPERATING SYSTEM</b>	Android Automotive
<b>RADIO</b>	AM/FM/DAB+
<b>INTERNAL STORAGE CAPACITY</b>	32GB
<b>SMARTPHONE INTEGRATION</b>	USB 3.0 socket
	Wi-Fi connectivity
	Android Auto / Apple CarPlay compatible
	Phone storage pocket with wireless charging facility

DRIVER CONTROLS	
<b>ENGINE</b>	Idle speed control
	Cruise control
<b>TRANSMISSION (AT ONLY)</b>	Push button gear selection control
<b>GENERAL CONTROLS</b>	Headlamp on/off and levelling, windscreen wipers (2 speed and intermittent modes), washers, exhaust brake, turn signals
	Cross lock engage switch

INSTRUMENTATION	
<b>MULTI INFORMATION DISPLAY</b>	Vehicle systems status
	Low fuel level alert
	Fuel consumption information
	Service interval alerts
	Hourmeter
<b>GENERAL INSTRUMENTATION</b>	Adjustable vehicle speed warning
	Speedometer and tachometer
	Digital odometer with integrated dual tripmeters
	Transmission oil level, oil life, filter life, and condition monitor display (AT only)
	Engine coolant temperature, fuel level and air pressure gauges

WEIGHTS (kg)							
MODELS	RATINGS*		LOADING LIMIT* (at ground)		CAB CHASSIS WEIGHT #		
	GVM	GCM	FRONT	REAR	FRONT	REAR	TOTAL
FXR 165-350 LWB	16,500	38,000	6,600	10,400	3,985	2,020	6,005
FXD 165-350 LWB	16,500	38,000	6,600	10,400	3,995	1,890	5,885
FXD 165-350 AUTO LWB	16,500	38,000	6,600	10,400	4,120	1,930	6,050
FXD 165-350 XLWB	16,500	38,000	6,600	10,400	3,945	1,920	5,865

\* Vehicle ratings and front/rear weight limits are subject to government regulatory requirements and weight distribution analysis. Consult your Isuzu dealer to select the correct vehicle for your specific application. # Cab chassis only as supplied and including 10 litres of fuel.

DIMENSIONS (mm)													(m)
MODELS	WB	OAL	FOH	ROH	EA	CE	RT	ORT	CH	FFA (unladen)	RFA (unladen)	RFH (unladen)	TURNING CIRCLE kerb to kerb
FXR 165-350 LWB	5,740	10,000	1,480	2,780	5,060	7,960	1,840	2,445	2,980	920	1,115	1,160	21.7
FXD 165-350 LWB / AUTO LWB	5,740	10,000	1,480	2,780	5,060	7,960	1,840	2,445	2,980	920	1,035	1,060	21.7
FXD 165-350 XLWB	6,200	10,460	1,480	2,780	5,520	8,420	1,840	2,445	2,980	920	1,035	1,055	23.4

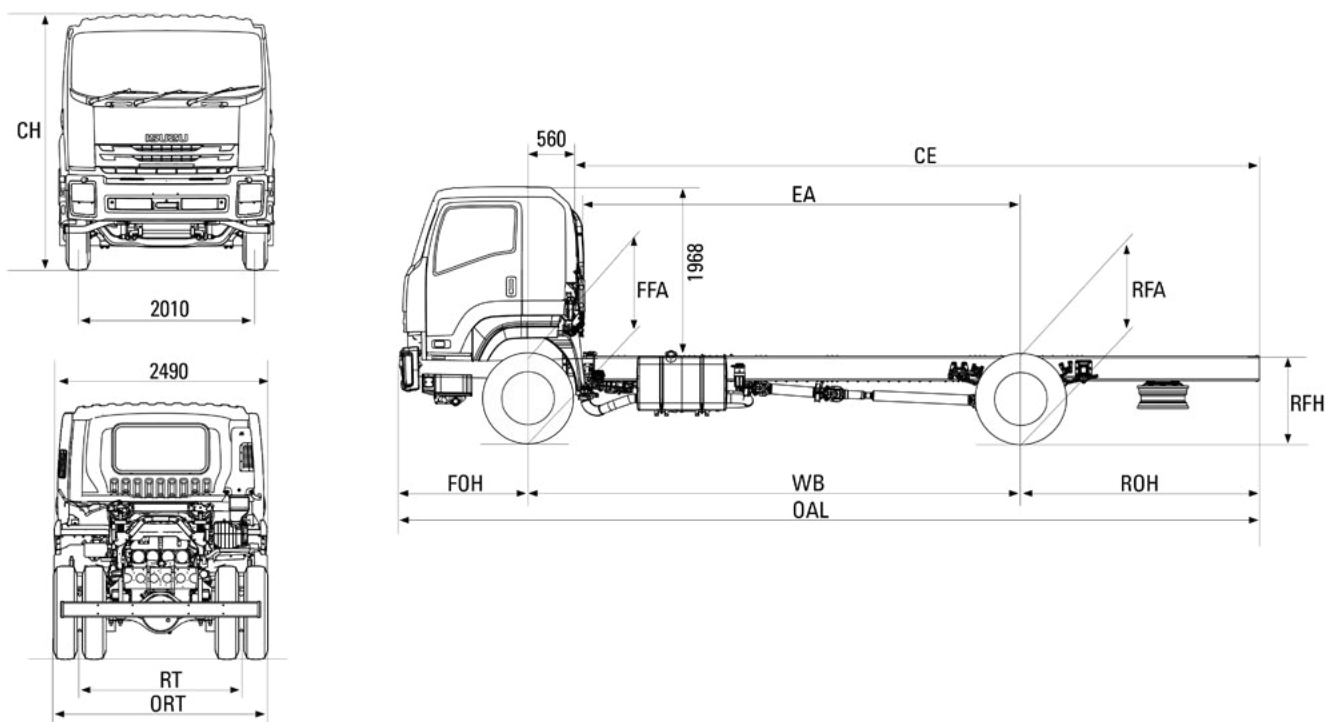

PERFORMANCE (calculated - typical paved road)				
		GEARED SPEED <sup>^</sup> (top gear at peak power engine rpm)	LOW SPEED GRADEABILITY (lowest forward gear assuming no wheel slip)	ENGINE SPEED (top gear at 100 km/h)
FXR/FXD 165-350	At 16,500 kg GVM	113 km/h @ 2,000 rpm	66%	1,765 rpm
FXD 165-350 AUTO	At 16,500 kg GVM	118 km/h @ 2,000 rpm	83%	1,690 rpm

<sup>^</sup> Maximum speed achievable depends on vehicle frontal area as well as other factors. Consult your Isuzu dealer for more detailed information. Vehicle is speed limited to 100km/h.

ORDER CODES	
MODELS	CODES
FXR 165-350 LWB	FH-FXRJJ-D22
FXD 165-350 LWB	FH-FXDJJ-D22
FXD 165-350 AUTO LWB	FH-FXDJJ-N23
FXD 165-350 XLWB	FH-FXDJJ-E22

Subject to the conditions outlined in the IAL New Vehicle Warranty, Isuzu FX series models carry a standard factory warranty which covers the owner for the first 72 months or 600,000 kilometres or 10,000 Engine Hours (whichever comes first). All Isuzu warranties are subject to mandatory prescribed terms under Australian Consumer Law including consumer guarantees. Harsh Conditions variations to standard factory warranty may apply. For more details visit the Isuzu website at [www.isuzu.com.au](http://www.isuzu.com.au) which explains Isuzu warranties in more detail, or alternatively contact your local Isuzu Truck dealer. All warranties commence from date of initial delivery.

ISUZU AUSTRALIA LIMITED ABN 97 006 962 572 ("IAL"). The information in this spec sheet was correct at time of printing, but all measurements, specifications and equipment are subject to change without notice. Some equipment may have been changed and/or is available at extra cost. IAL may make changes at any time without notice, in prices, colours, materials, equipment and models. IAL makes all reasonable attempts to ensure the availability of all vehicles and equipment. The information in this spec sheet is general in nature. Your Isuzu dealer can confirm all measurements, specifications and vehicle / equipment availability upon request. To the extent permitted by the law, IAL is not liable to any person as result of reliance on the content of this spec sheet.