

FVL 240-300 AUTO FREIGHTPACK



Truck images shown may vary from actual model specification - Contact Isuzu for further details.

WEIGHT RATINGS*

GVM 24,000 kg
GCM 32,000 kg

ENGINE

POWER 221 kW @ 2,400 rpm
TORQUE 981 Nm @ 1,450 rpm

TRANSMISSION

6 speed automatic transmission (AT)

* Refer to back page for detailed weight rating information

READY TO WORK	
STANDARD FEATURES	14 pallet (nominal) curtainside body
	Easy glide curtains with quick release "Lightning" latches
	Lightweight side gates
	5mm checkerplate floor and headboard with load restraints
	Safety yellow coloured body steps and grab handles
	Removable rear step facilitates tailgate loader installation
	Underbody mounted storage box
	LED lighting for body interior and access steps
	Body mounted air deflector
Isuzu low light capable reversing camera	

INTELLIGENT SAFETY		
ACTIVE SAFETY ADVANCED DRIVER ASSISTANCE SYSTEMS (ADAS)	Electronic Stability Control	(ESC)
	Anti Lock Braking System	(ABS)
	Anti Skid Regulator	(ASR)
	Electronic Braking System	(EBS)
	Cab Tilt Warning	(CTW)
	Low light capable reversing camera	
PASSIVE SAFETY CABIN OCCUPANT SAFETY SYSTEMS (COSS)	Driver and front passenger airbags	
	Driver and front left hand passenger seatbelt pretensioners	
	ECE-R29 cab with side anti-intrusion beams	
	Door mounted cornering lamps	

ISUZU CARE	
WARRANTY	6 Year Standard Warranty
	300,000 km / no hours stipulation
ROADSIDE ASSIST	6 Year Roadside Support
	24/7 Unlimited km
READY TO WORK BODY WARRANTY	3 Year / Unlimited km Standard Warranty

SERVICE AGREEMENTS			
OPTIONAL SERVICE PACKAGES	ESSENTIALS	ESSENTIALS PLUS	TOTAL
SCHEDULED SERVICINGS	●	●	●
CONSUMABLES		●	●
ENGINE, TRANSMISSION & DRIVELINE			●
EXTRAS	After-hours Servicing, Glass, Fuel Card, Pickup - Dropoff		



Subject to the conditions outlined in the IAL New Vehicle Warranty. For further information please visit isuzu.com.au or contact your local dealer.

FVL 240-300 AUTO FREIGHTPACK

ENGINE	
DESCRIPTION	Isuzu 6HK1-TCS
TYPE	6 cylinder 24 valve SOHC
DISPLACEMENT	7,790 cc
COMPRESSION RATIO	17.5:1
BORE X STROKE	115mm x 125mm
POWER	221kW (300PS) @ 2,400 RPM (DIN NET)
TORQUE	981Nm @ 1,450 RPM (DIN NET)
INDUCTION	Electronically controlled variable nozzle turbocharger with air-to air intercooler.
FUEL INJECTION	Direct injection high pressure common rail system.
EMISSION CONTROL	Cooled EGR with exhaust Diesel Particulate Diffuser (DPD). ADR 80/03 (Euro V / EEV) compliant.

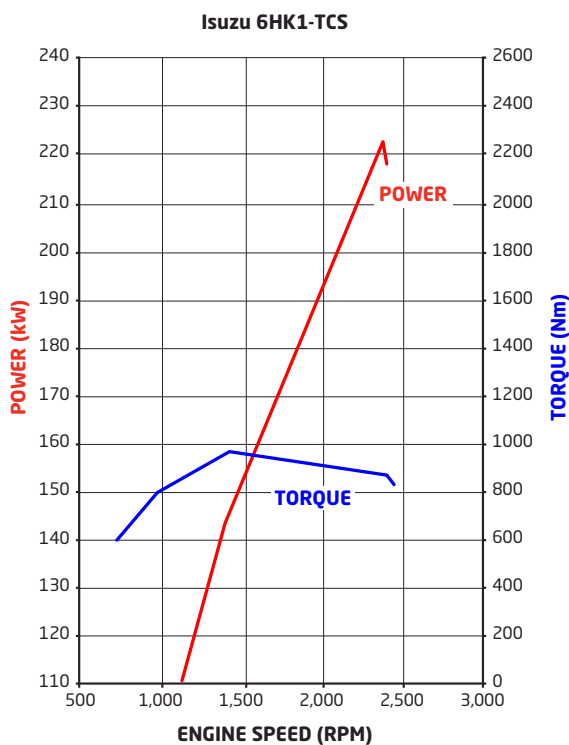

TRANSMISSION															
AT	Description: Allison 3500														
	Type: 6 speed automatic														
	Ratios:														
	<table border="1"> <thead> <tr> <th>1st</th> <th>2nd</th> <th>3rd</th> <th>4th</th> <th>5th</th> <th>6th</th> <th>Rev</th> </tr> </thead> <tbody> <tr> <td>4.59</td> <td>2.25</td> <td>1.54</td> <td>1.00</td> <td>0.75</td> <td>0.65</td> <td>5.00</td> </tr> </tbody> </table>	1st	2nd	3rd	4th	5th	6th	Rev	4.59	2.25	1.54	1.00	0.75	0.65	5.00
	1st	2nd	3rd	4th	5th	6th	Rev								
4.59	2.25	1.54	1.00	0.75	0.65	5.00									
Power Take Off facility: LHS and top openings on transmission bellhousing. Engine driven PTO drive gear.															
Other features: 5th generation electronic controls with adaptive shift. Long life TranSynd synthetic fluid															

AXLES	
FRONT	Description: Meritor FG941
	Type: Reverse Elliot I-beam
	Capacity: 6,600 kg
REAR	Description: Drive axle: Meritor RS-23-161G Lazy axle: Meritor TR4670
	Type: Single drive + lazy axle combination
	Capacity: 20,000kg combined
	Ratio: 6.428

SUSPENSION	
FRONT	Type: Single stage alloy steel taper-leaf springs
	Other features: Double acting hydraulic shock absorbers. Stabiliser bar.
REAR	Description: Hendrickson HAS400
	Type: Airbag
	Capacity: 18,100kg at ground

BRAKES	
DESCRIPTION	Meritor 'Q-Plus'
TYPE	Full air 'S-Cam' front and rear drum brakes
DIAMETER X WIDTH FRONT	419 x 127mm
DIAMETER X WIDTH REAR	419 x 178mm
PARK BRAKE	Spring park brake acting on all rear wheels
AUXILLIARY BRAKE	Air controlled exhaust brake

STEERING	
TYPE	Power assisted recirculating ball
GEAR RATIO	22.4:1
TURNS LOCK TO LOCK	5.4
WHEEL LOCK ANGLE	45° (inside wheel) / 35° (outside wheel)

WHEELS & TYRES	
FRONT	Wheels: 22.5 x 8.25 ten stud ISO standard steel wheels
	Tyres: 235/75R17.5 132/130M Michelin X Multi Z Tubeless
	Drive axle tyre rating: 7,600 kg
REAR	Wheels: 22.5 x 8.25 ten stud ISO standard steel wheels
	Drive axle: 11R22.5 148/145L Michelin X Multi D Tubeless
	Lazy axle: 11R22.5 148/145L Michelin X Multi Z 2 Tubeless
	Steer axle tyre rating: 23,200 kg
Spare: Spare wheel and X Multi Z tyre assembly supplied. Winch type carrier.	

CHASSIS FRAME	
TYPE	Cold rivetted ladder frame with parallel side rails.
MATERIAL	SAPH440 steel sidemembers
DIMENSIONS	Side rail (mm): 258x85x10.0 Rear frame width (mm): 850

FUEL TANK	
TYPE	Frame mounted aluminium fuel tank
CAPACITY	400L
FUEL CAP	Lockable

ELECTRICAL SYSTEM	
TYPE	24 volt
ALTERNATOR	90 amp
STARTER MOTOR	5.0kW
BATTERY	2 x 115E41L (651 CCA) batteries connected in series
CAN BUS PROVISION	Underdash CAN system access plug for connection to a Fleet Management System (FMS) (not supplied).

CABIN SPECIFICATIONS & APPOINTMENTS

CABIN GENERAL FEATURES	
ENGINE ACCESS	Electro-hydraulic cab tilt
CAB MOUNTING	Rear coil spring suspension with hydraulic shock absorbers
STEPS	Heavy duty anti slip steps
DOORS	90° opening internally reinforced front doors
MIRRORS	Heated and powered exterior main mirrors with flat glass and additional independantly adjustable convex "spot" mirrors
WIPERS	Two speed windscreen wipers with intermittent wipe mode
EXTERIOR LIGHTING	LED main beam and halogen high beam headlamp assembly with position lamp
	Roof mounted clearance lamps
	Front foglamps
AUDIBLE WARNING	Reverse alarm
GRILLE	Chrome
FRONT BUMPER	Body coloured air dam type
SECURITY	Central locking with remote keyless entry & immobiliser

CABIN INTERIOR	
SEATING	Isri 6860/875 NTS air suspension driver's seat
SEATBELTS	3-point lap sash seatbelts in all outboard seating positions. Driver seatbelt integrated with driver seat. Centre seat lap belts.
STEERING COLUMN	Tilt/telescopic adjustable
ENTRY ASSIST GRIPS	Door & roof pillar mounted
DOOR WINDOWS	Electric control
STORAGE	Overhead compartments
	Twin cup holders
	Centre console box & storage tray
	Front door pockets
POWER OUTLET	24V cigarette lighter
AIRCONDITIONING	Auto control
INTERIOR LIGHTING	Fluorescent lamp
REAR COMPARTMENT	ADR 42 compliant sleeper with mattress

MYISUZU CO-PILOT AUDIO VISUAL UNIT	
SCREEN TYPE	10.1" 1080p High Definition with capacitive touch
NAVIGATION	Truck tailored GPS based system + live feed traffic alerts and live feed route optimisation via smartphone link (live feed updates are provided for 3 years)
OPERATING SYSTEM	Android Automotive
RADIO	AM/FM/DAB+
INTERNAL STORAGE CAPACITY	32GB
	USB 3.0 socket
SMARTPHONE INTEGRATION	Wi-Fi connectivity
	Android Auto / Apple CarPlay compatible
	Phone storage pocket with wireless charging facility

DRIVER CONTROLS	
SAFETY SYSTEMS	ESC on/off
ENGINE	Idle speed control
	Cruise control
	DPD manual regeneration switch
TRANSMISSION	Pushbutton gear selection control
GENERAL CONTROLS	Headlamp on/off and levelling, windscreen wipers (2 speed and intermittent modes), washers, exhaust brake, turn signals

INSTRUMENTATION	
MULTI INFORMATION DISPLAY	CTW indicator
	Low engine oil level alert
	Vehicle systems status
	Low fuel level alert
	Fuel consumption information
	Service interval alerts
	Hourmeter
GENERAL INSTRUMENTATION	Adjustable vehicle speed warning
	Speedometer & tachometer
	Digital odometer with integrated dual tripmeters
	Engine coolant temperature, fuel level and air pressure guages

FVL 240-300 AUTO FREIGHTPACK

WEIGHTS (kg)							
MODELS	RATINGS*		LOADING LIMIT* (at ground)		WEIGHT #		
	GVM	GCM	FRONT	REAR	FRONT	REAR	TOTAL
FVL 240-300 AUTO FREIGHTPACK	24,000	32,000	6,600	18,100	4,220	5,650	9,870

* Vehicle ratings and front/rear weight limits are subject to government regulatory requirements and weight distribution analysis. Consult your Isuzu dealer to select the correct vehicle for your specific application.

Vehicle as supplied and including 10 litres of fuel.

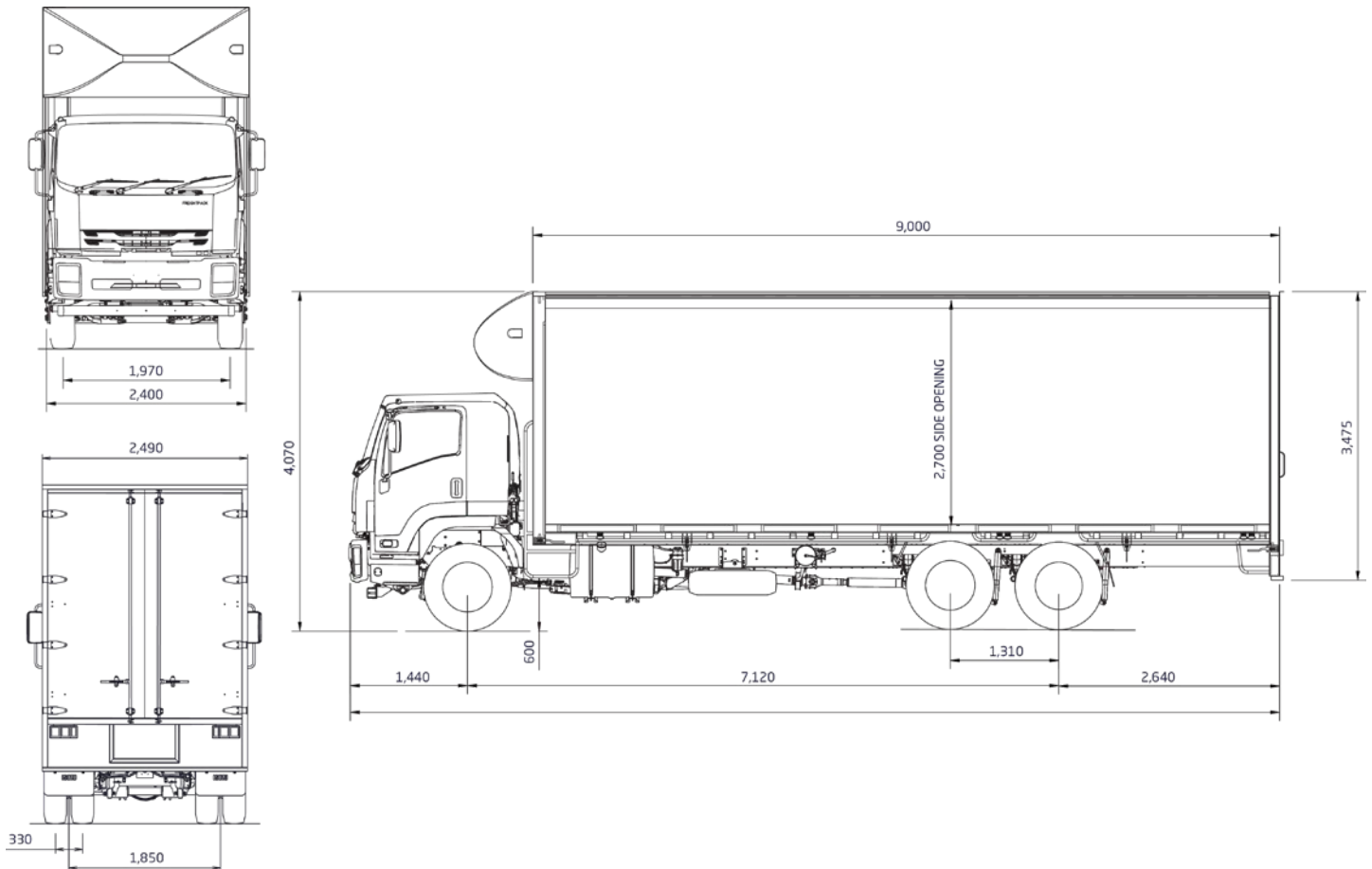

PERFORMANCE (calculated - typical paved road)				
		GEARED SPEED~ (top gear at peak power engine rpm)	LOW SPEED GRADEABILITY (lowest forward gear assuming no wheel slip)	ENGINE SPEED (top gear at 100 km/h)
FVL 240-300 AUTO FREIGHTPACK	at 24,000kg GVM	111 km/h @ 2,400 RPM	42%	2,160 RPM

* Maximum speed achievable depends on vehicle frontal area as well as other factors. Consult your Isuzu dealer for more detailed information.

ORDER CODES	
Models	Codes
FVL 240-300 AUTO LWB FREIGHTPACK	FH-FVJZ-NE2

Subject to the conditions outlined in the IAL New Vehicle Warranty, Isuzu F series models carry a standard factory warranty which covers the owner for the first 72 months or 300,000 kilometres, no hours stipulation. All Isuzu warranties are subject to mandatory prescribed terms under Australian Consumer Law including consumer guarantees. Harsh Conditions variations to standard factory warranty may apply. For more details visit the Isuzu website at www.isuzu.com.au which explains Isuzu warranties in more detail, or alternatively contact your local Isuzu Truck dealer. All warranties commence from date of initial delivery.

ISUZU AUSTRALIA LIMITED ABN 97 006 962 572 ("IAL"). The information in this spec sheet was correct at time of printing, but all measurements, specifications and equipment are subject to change without notice. Some equipment may have been changed and/or is available at extra cost. IAL may make changes at any time without notice, in prices, colours, materials, equipment and models. IAL makes all reasonable attempts to ensure the availability of all vehicles and equipment. The information in this spec sheet is general in nature. Your Isuzu dealer can confirm all measurements, specifications and vehicle / equipment availability upon request. To the extent permitted by the law, IAL is not liable to any person as result of reliance on the content of this spec sheet.