

FSR 140/120-260 TIPPER



WEIGHT RATINGS*

GVM 14,000 kg / 12,000 kg
GCM 21,000 kg

ENGINE

POWER 191 kW @ 2,400 rpm
TORQUE 761 Nm @ 1,450 - 2400 rpm

TRANSMISSION

6 speed manual transmission (MT)

* Refer to back page for detailed weight rating information

ISUZU CARE	
WARRANTY	6 Year Standard Warranty
	300,000 km / no hours stipulation
	3 Year / Unlimited km Body Equipment
ROADSIDE ASSIST	6 Year Roadside Support
	24/7 Unlimited km

SERVICE AGREEMENTS			
OPTIONAL SERVICE PACKAGES	ESSENTIALS	ESSENTIALS PLUS	TOTAL
SCHEDULED SERVICINGS	●	●	●
CONSUMABLES		●	●
ENGINE, TRANSMISSION & DRIVELINE			●
EXTRAS	After-hours Servicing, Glass, Fuel Card, Pickup - Dropoff		



Subject to the conditions outlined in the IAL New Vehicle Warranty. For further information please visit isuzu.com.au or contact your local dealer.

INTELLIGENT SAFETY		
ACTIVE SAFETY	Anti Lock Braking System	(ABS)
	Anti Skid Regulator	(ASR)
	Hill Start Aid	(HSA)
	Cab Tilt Warning	(CTW)
PASSIVE SAFETY CABIN OCCUPANT SAFETY SYSTEMS (COSS)	Low light capable reversing camera	
	Driver & front passenger airbags	
	Driver & front left hand passenger seatbelt pretensioners	
	ECE-R29 cab with side anti-intrusion beams	
	Door mounted cornering lamps	

READY TO WORK	
STANDARD FEATURES	All steel body. Auto release two-way tailgate
	Auto release body lockdown hook
	Shovel rack. LHS and RHS rope rails. Yellow painted body mounted non-slip side steps and grab handles
	Large capacity secure storage box mounted between cab and tipper body
	20 sec. raise/20 sec. lower time
	Cubic volume: 5.2m ³
	Deck plate thickness: 6.0mm
	Side/front/tail plate thickness: 3.2mm

ENGINE	
DESCRIPTION	Isuzu 6HK1-TCC
TYPE	6 cylinder 24 valve SOHC
DISPLACEMENT	7,790 cc
COMPRESSION RATIO	17.5:1
BORE X STROKE	115mm x 125mm
POWER	191kW (260PS) @ 2,400 RPM (DIN NET)
TORQUE	761Nm @ 1,450 RPM - 2,400 RPM (DIN NET)
INDUCTION	Electronically controlled variable nozzle turbocharger with air-to air intercooler.
FUEL INJECTION	Direct injection high pressure common rail system.
EMISSION CONTROL	Cooled EGR with exhaust Diesel Particulate Diffuser (DPD). ADR 80/03 (Euro V / EEV) compliant.

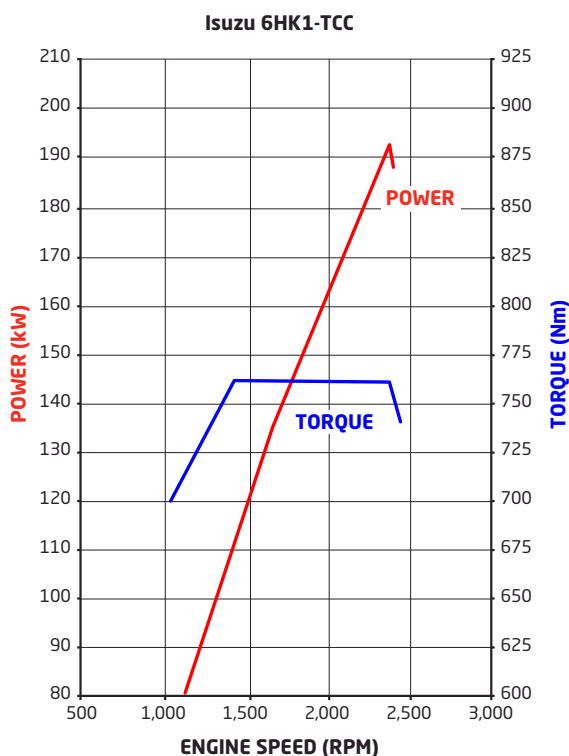

TRANSMISSION															
MT	CLUTCH	Type: Single plate with air assisted hydraulic control Clutch plate diameter: 381 mm Clutch lining area: 1,363 cm ²													
	GEARBOX	Description: Isuzu MZW-6P Type: 6 speed with synchromesh on gears 2-6 Ratios: <table border="1" style="display: inline-table; vertical-align: middle;"> <thead> <tr> <th>1st</th> <th>2nd</th> <th>3rd</th> <th>4th</th> <th>5th</th> <th>6th</th> <th>Rev</th> </tr> </thead> <tbody> <tr> <td>6.615</td> <td>4.095</td> <td>2.358</td> <td>1.531</td> <td>1.000</td> <td>0.722</td> <td>6.615</td> </tr> </tbody> </table> Other features: Air assisted shift, full pressure oil lubrication	1st	2nd	3rd	4th	5th	6th	Rev	6.615	4.095	2.358	1.531	1.000	0.722
1st	2nd	3rd	4th	5th	6th	Rev									
6.615	4.095	2.358	1.531	1.000	0.722	6.615									

AXLES		
FRONT	Description:	Isuzu F050
	Type:	Reverse Elliot I-beam
	Capacity:	5,000kg
REAR	Description:	Isuzu R090
	Type:	Single drive
	Capacity:	9,000kg
	Ratio:	4.555

SUSPENSION		
FRONT	Type:	Single stage alloy steel taper-leaf springs
	Other features:	Double acting hydraulic shock absorbers. Stabiliser bar.
REAR	Type:	Multi-leaf main spring, multi leaf helper spring

BRAKES	
TYPE	Air over hydraulic dual circuit front and rear drum brakes.
DIAMETER X WIDTH FRONT	370 x 150mm
DIAMETER X WIDTH REAR	370 x 150mm
PARK BRAKE	Spring park brake acting on all rear wheels
AUXILIARY BRAKE	Air controlled exhaust brake

STEERING	
TYPE	Power assisted recirculating ball
GEAR RATIO	16.1 - 18.8:1
TURNS LOCK TO LOCK	4.1
WHEEL LOCK ANGLE	44° (inside wheel) / 34° (outside wheel)

WHEELS & TYRES		
FRONT	Wheels:	19.5 x 6.75 eight stud ISO standard steel wheels
	Tyres:	265/70R19.5 140/138M Michelin X Multi Z Tubeless
	Steer axle tyre rating	5,000kg
REAR	Wheels:	19.5 x 6.75 eight stud ISO standard steel wheels
	Tyres:	265/70R19.5 140/138M Michelin X Multi Z Tubeless
	Drive axle tyre rating	9,440kg
Spare: Spare wheel and tyre assembly supplied.		

CHASSIS FRAME	
TYPE	Cold rivetted ladder frame with parallel side rails.
MATERIAL	HT540A steel sidemembers
DIMENSIONS	Side rail (mm): 225 x 70 x 6.0 Rear frame width (mm): 840

FUEL TANK	
TYPE	Frame mounted steel fuel tank
CAPACITY	200L
FUEL CAP	Lockable

ELECTRICAL SYSTEM	
TYPE	24 volt
ALTERNATOR	90 amp
STARTER MOTOR	5.0 kw
BATTERY	2 x 115E41L (651 CCA) batteries connected in series
CAN BUS PROVISION	Underdash CAN system access plug for connection to a Fleet Management System (FMS) (not supplied)

CABIN SPECIFICATIONS & APPOINTMENTS

CABIN GENERAL FEATURES	
ENGINE ACCESS	Manual cab tilt to 45° with torsion bar assistance
STEPS	Heavy duty anti slip steps
DOORS	90° opening internally reinforced front doors
MIRRORS	Heated and powered exterior main mirrors with flat glass & additional independantly adjustable convex "spot" mirrors
WIPERS	Two speed windscreen wipers with intermittent wipe mode
EXTERIOR LIGHTING	LED main beam & halogen high beam headlamp assembly with position lamp
	Roof mounted clearance lamps
	Front foglamps
AUDIBLE WARNING	Reverse alarm
GRILLE	Chrome
FRONT BUMPER	Body coloured air dam type
SECURITY	Central locking with remote keyless entry & immobiliser

CABIN INTERIOR	
SEATING	Isri 6860/875 NTS air suspension driver's seat
	Front passenger adjustable bucket seat & front centre seat with folding seat back
SEATBELTS	3-point lap sash seatbelts in all outboard seating positions. Driver seatbelt integrated with driver seat. Centre seat lap belts.
STEERING COLUMN	Tilt/telescopic adjustable
ENTRY ASSIST GRIPS	Door & roof pillar mounted
DOOR WINDOWS	Electric control
STORAGE	Overhead compartments
	Twin cup holders
	Centre console box & storage tray
	Front door pockets
POWER OUTLET	24V cigarette lighter
AIRCONDITIONING	Auto control
INTERIOR LIGHTING	Fluorescent lamp

MYISUZU CO-PILOT AUDIO VISUAL UNIT	
SCREEN TYPE	10.1" 1080p High Definition with capacitive touch
NAVIGATION	Truck tailored GPS based system + live feed traffic alerts and live feed route optimisation via smartphone link (live feed updates are provided for 3 years)
OPERATING SYSTEM	Android Automotive
RADIO	AM/FM/DAB+
INTERNAL STORAGE CAPACITY	32GB
SMARTPHONE INTEGRATION	USB 3.0 socket
	Wi-Fi connectivity
	Android Auto / Apple CarPlay compatible
	Phone storage pocket

DRIVER CONTROLS	
SAFETY SYSTEMS	ASR on/off, HSA on/off/sensitivity adjust
ENGINE	Idle speed control
	Cruise control
	DPD manual regeneration switch
GENERAL CONTROLS	Headlamp on/off and levelling, windscreen wipers (2 speed and intermittent modes), washers, exhaust brake, turn signals
	PTO engage switch
	Tip body raise and lower lever with safety release mechanism.

INSTRUMENTATION	
MULTI INFORMATION DISPLAY	CTW indicator
	Low engine oil level alert
	Vehicle systems status
	Low fuel level alert
	Fuel consumption information
	Service interval alerts
	Hourmeter
	Adjustable vehicle speed warning
	PTO engaged indicator
	GENERAL INSTRUMENTATION
Digital odometer with integrated dual tripmeters	
Engine coolant temperature, fuel level and air pressure guages	

FSR 140/120-260 TIPPER

WEIGHTS (kg)							
MODELS	RATINGS*		LOADING LIMIT* (at ground)		WEIGHT #		
	GVM	GCM	FRONT	REAR	FRONT	REAR	TOTAL
FSR 140/120-260 TIPPER	14,000 / 12,000	21,000	5,000	9,000	2,940	2,980	5,920

* Vehicle ratings and front/rear weight limits are subject to government regulatory requirements and weight distribution analysis. Consult your Isuzu dealer to select the correct vehicle for your specific application.

Vehicle as supplied and including 10 litres of fuel.

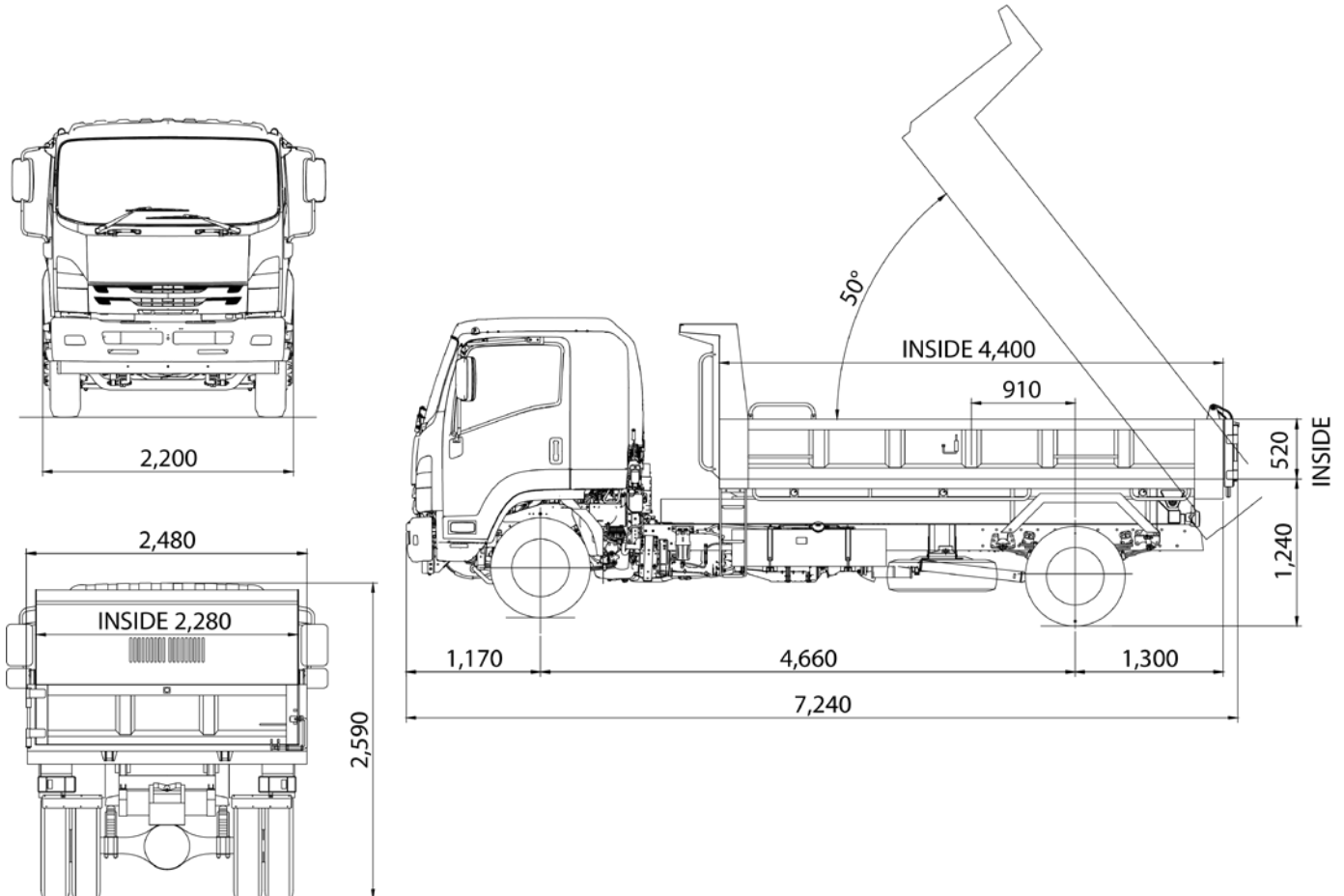

Turning Circle (kerb to kerb)
16.7 m

PERFORMANCE (calculated - typical paved road)				
		GEARED SPEED~ (top gear at peak power engine rpm)	LOW SPEED GRADEABILITY (lowest forward gear assuming no wheel slip)	ENGINE SPEED (top gear at 100 km/h)
FSR 120-260	at 12,000kg GVM	116 km/h @ 2,400 RPM	41%	2,070 RPM
FSR 140-260	at 14,000kg GVM	116 km/h @ 2,400 RPM	35%	2,070 RPM

* Maximum speed achievable depends on vehicle frontal area as well as other factors. Consult your Isuzu dealer for more detailed information.

ORDER CODES	
Models	Codes
FSR 140/120-260 TIPPER	FH-FSRZG-B22

Subject to the conditions outlined in the IAL New Vehicle Warranty, Isuzu F series models carry a standard factory warranty which covers the owner for the first 72 months or 300,000km, no hours stipulation. All Isuzu warranties are subject to mandatory prescribed terms under Australian Consumer Law including consumer guarantees. Harsh Conditions variations to standard factory warranty may apply. For more details visit the Isuzu website at www.isuzu.com.au which explains Isuzu warranties in more detail, or alternatively contact your local Isuzu Truck dealer. All warranties commence from date of initial delivery.

ISUZU AUSTRALIA LIMITED ABN 97 006 962 572 ("IAL"). The information in this spec sheet was correct at time of printing, but all measurements, specifications and equipment are subject to change without notice. Some equipment may have been changed and/or is available at extra cost. IAL may make changes at any time without notice, in prices, colours, materials, equipment and models. IAL makes all reasonable attempts to ensure the availability of all vehicles and equipment. The information in this spec sheet is general in nature. Your Isuzu dealer can confirm all measurements, specifications and vehicle / equipment availability upon request. To the extent permitted by the law, IAL is not liable to any person as result of reliance on the content of this spec sheet.