

## FRR 110-240 TIPPER



### WEIGHT RATINGS\*

<b>GVM</b>	11,000 kg
<b>GCM</b>	16,000 kg

### ENGINE

<b>POWER</b>	177 kW @ 2,400 rpm
<b>TORQUE</b>	765 Nm @ 1,600 rpm

### TRANSMISSION

6 speed manual transmission (MT)
6 speed automatic transmission (AMT)

\* Refer to back page for detailed weight rating information

ISUZU CARE	
<b>WARRANTY</b>	6 Year Standard Warranty
	300,000 km / no hours stipulation
	3 Year / Unlimited km Body Equipment
<b>ROADSIDE ASSIST</b>	6 Year Roadside Support
	24/7 Unlimited km

SERVICE AGREEMENTS			
OPTIONAL SERVICE PACKAGES	ESSENTIALS	ESSENTIALS PLUS	TOTAL
<b>SCHEDULED SERVICINGS</b>	●	●	●
<b>CONSUMABLES</b>		●	●
<b>ENGINE, TRANSMISSION &amp; DRIVELINE</b>			●
<b>EXTRAS</b>	After-hours Servicing, Glass, Fuel Card, Pickup - Dropoff		

INTELLIGENT SAFETY		
<b>ACTIVE SAFETY ADVANCED DRIVER ASSISTANCE SYSTEMS (ADAS)</b>	Advanced Emergency Braking	<b>(AEB)</b>
	Forward Collision Warning	<b>(FCW)</b>
	Distance Warning System	<b>(DWS)</b>
	Lane Departure Warning	<b>(LDW)</b>
	Electronic Stability Control	<b>(ESC)</b>
	Anti Lock Braking System	<b>(ABS)</b>
	Hill Start Aid	<b>(HSA)</b>
	Cab Tilt Warning	<b>(CTW)</b>
<b>PASSIVE SAFETY CABIN OCCUPANT SAFETY SYSTEMS (COSS)</b>	Low light capable reversing camera	
	Driver & front passenger airbags	
	Driver & front left hand passenger seatbelt pretensioners	
	ECE-R29 cab with side anti-intrusion beams	
	Door mounted cornering lamps	



Subject to the conditions outlined in the IAL New Vehicle Warranty. For further information please visit [isuzu.com.au](http://isuzu.com.au) or contact your local dealer.

READY TO WORK	
<b>STANDARD FEATURES</b>	All steel body with drop sides. Auto release two-way tailgate
	Auto release body lockdown hook
	Shovel rack. LHS and RHS rope rails. Non-slip side steps
	20 sec. raise/20 sec. lower time
	Cubic volume: 3.8 m <sup>3</sup>
	Deck plate thickness: 6.0 mm
	Side/front/tail plate thickness: 3.2 mm

ENGINE	
<b>DESCRIPTION</b>	Isuzu N-4HK1-TCH
<b>TYPE</b>	4 cylinder 16 valve SOHC
<b>DISPLACEMENT</b>	5,193 cc
<b>COMPRESSION RATIO</b>	16.5:1
<b>BORE X STROKE</b>	115mm x 125mm
<b>POWER</b>	177kW (240PS) @ 2,400 RPM (DIN NET)
<b>TORQUE</b>	765Nm @ 1,600 RPM (DIN NET)
<b>INDUCTION</b>	Low pressure turbocharger and high pressure Variable Geometry System (VGS) turbocharger sequentially operated and with with air-to air intercooler.
<b>FUEL INJECTION</b>	Direct injection high pressure common rail system. Exhaust pipe fuel injection for DPD regeneration
<b>EMISSION CONTROL</b>	Cooled EGR with exhaust Diesel Particulate Diffuser (DPD) . ADR 80/03 (Japan PNLT) compliant.

AXLES	
<b>FRONT</b>	<b>Description:</b> Isuzu F041
	<b>Type:</b> Reverse Elliot I-beam
	<b>Capacity:</b> 4,100 kg
<b>REAR</b>	<b>Description:</b> Isuzu R077
	<b>Type:</b> Single drive
	<b>Capacity:</b> 7,700 kg
	<b>Ratio:</b> 4.875

SUSPENSION	
<b>FRONT</b>	<b>Type:</b> Single stage alloy steel multi-leaf springs
	<b>Other features:</b> Double acting hydraulic shock absorbers. Stabiliser bar.
<b>REAR</b>	<b>Type:</b> Multi-leaf main spring, multi leaf helper spring

Isuzu N-4HK1-TCH

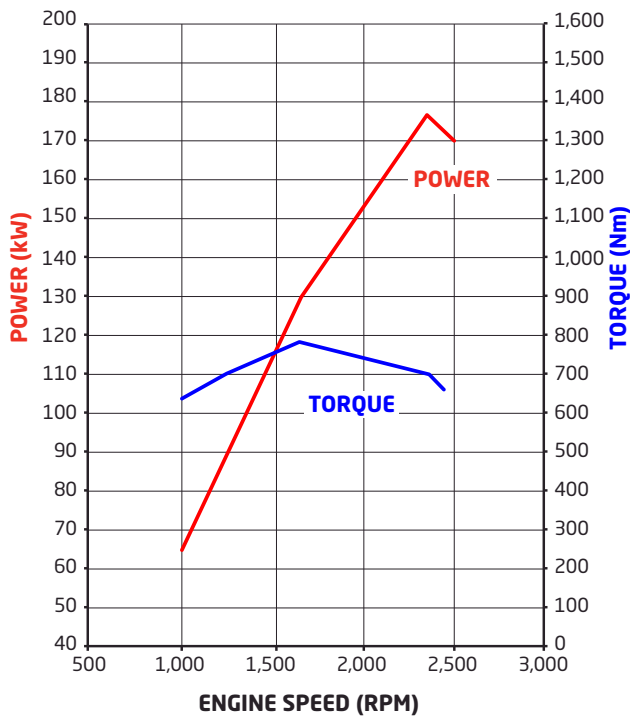

BRAKES	
<b>TYPE</b>	Air over hydraulic dual circuit front and rear drum brakes.
<b>DIAMETER X WIDTH FRONT</b>	320 x 120 mm
<b>DIAMETER X WIDTH REAR</b>	320 x 145 mm
<b>PARK BRAKE</b>	Spring park brake acting on all rear wheels
<b>AUXILIARY BRAKE</b>	Air controlled exhaust brake

STEERING	
<b>TYPE</b>	Power assisted recirculating ball
<b>GEAR RATIO</b>	16.1 - 18.8:1
<b>TURNS LOCK TO LOCK</b>	4.1
<b>WHEEL LOCK ANGLE</b>	52° (inside wheel) / 39° (outside wheel)

WHEELS & TYRES	
<b>FRONT</b>	<b>Wheels:</b> 17.5 x 6.75 six stud steel wheels
	<b>Tyres:</b> 235/75R17.5 132/130M Michelin X Multi Z Tubeless
	<b>Steer axle tyre rating</b> 4,000 kg
<b>REAR</b>	<b>Wheels:</b> 17.5 x 6.75 six stud steel wheels
	<b>Tyres:</b> 235/75R17.5 132/130M Michelin X Multi Z Tubeless
	<b>Drive axle tyre rating:</b> 7,600 kg
<b>Spare:</b> Spare wheel and tyre assembly supplied.	

TRANSMISSION															
<b>MT</b>	<b>CLUTCH</b>	<b>Type:</b> Single plate with air assisted hydraulic control <b>Clutch plate diameter:</b> 352 mm <b>Clutch lining area:</b> 1,164cm <sup>2</sup>													
	<b>GEARBOX</b>	<b>Description:</b> Isuzu MZW-6P <b>Type:</b> 6 speed with synchromesh on gears 2-6													
		<b>Ratios:</b> <table border="1"> <thead> <tr> <th>1st</th> <th>2nd</th> <th>3rd</th> <th>4th</th> <th>5th</th> <th>6th</th> <th>Rev</th> </tr> </thead> <tbody> <tr> <td>6.615</td> <td>4.095</td> <td>2.358</td> <td>1.531</td> <td>1.000</td> <td>0.722</td> <td>6.615</td> </tr> </tbody> </table> <b>Other features:</b> Air assisted shift, full pressure oil lubrication	1st	2nd	3rd	4th	5th	6th	Rev	6.615	4.095	2.358	1.531	1.000	0.722
1st	2nd	3rd	4th	5th	6th	Rev									
6.615	4.095	2.358	1.531	1.000	0.722	6.615									
<b>AMT</b>	<b>Description:</b> Isuzu MZW-6P <b>Type:</b> 6 speed with both fully automatic and clutchless manual operation modes														
	<b>Ratios:</b> <table border="1"> <thead> <tr> <th>1st</th> <th>2nd</th> <th>3rd</th> <th>4th</th> <th>5th</th> <th>6th</th> <th>Rev</th> </tr> </thead> <tbody> <tr> <td>6.615</td> <td>4.095</td> <td>2.358</td> <td>1.531</td> <td>1.000</td> <td>0.722</td> <td>6.615</td> </tr> </tbody> </table> <b>Other features:</b> Integrated automated wet clutch and torque convertor (TC) with lock up	1st	2nd	3rd	4th	5th	6th	Rev	6.615	4.095	2.358	1.531	1.000	0.722	6.615
	1st	2nd	3rd	4th	5th	6th	Rev								
6.615	4.095	2.358	1.531	1.000	0.722	6.615									

CHASSIS FRAME	
<b>TYPE</b>	Cold rivetted ladder frame with parallel side rails.
<b>MATERIAL</b>	HT540A steel sidemembers
<b>DIMENSIONS</b>	<b>Side rail (mm):</b> 225 x 70 x 6.0 <b>Rear frame width (mm):</b> 840

FUEL TANK	
<b>TYPE</b>	Frame mounted steel fuel tank
<b>CAPACITY</b>	200L
<b>FUEL CAP</b>	Lockable

ELECTRICAL SYSTEM	
<b>TYPE</b>	24 volt
<b>ALTERNATOR</b>	90 amp
<b>STARTER MOTOR</b>	5.0 kw
<b>BATTERY</b>	2 x 115E41L (651 CCA) batteries connected in series
<b>CAN BUS PROVISION</b>	Underdash CAN system access plug for connection to a Fleet Management System (FMS) (not supplied)

## CABIN SPECIFICATIONS & APPOINTMENTS

CABIN GENERAL FEATURES	
<b>ENGINE ACCESS</b>	Manual cab tilt to 45° with torsion bar assistance
<b>STEPS</b>	Heavy duty anti slip steps
<b>DOORS</b>	90° opening internally reinforced front doors
<b>MIRRORS</b>	Heated & powered exterior main mirrors with flat glass and additional independantly adjustable convex "spot" mirrors
<b>WIPERS</b>	Two speed windscreen wipers with intermittent wipe mode
<b>EXTERIOR LIGHTING</b>	LED main beam & halogen high beam headlamp assembly with position lamp
	Roof mounted clearance lamps
	Front foglamps
<b>AUDIBLE WARNING</b>	Reverse alarm
<b>GRILLE</b>	Body coloured
<b>FRONT BUMPER</b>	Body coloured air dam type
<b>SECURITY</b>	Central locking with remote keyless entry & immobiliser

CABIN INTERIOR	
<b>SEATING</b>	Isri 6860/875 NTS air suspension driver's seat
	Front passenger adjustable bucket seat and front centre seat with folding seat back.
<b>SEATBELTS</b>	3-point lap sash seatbelts in all outboard seating positions. Driver seatbelt integrated with driver seat. Centre seat lap belts.
<b>STEERING COLUMN</b>	Tilt/telescopic adjustable
<b>ENTRY ASSIST GRIPS</b>	Door & roof pillar mounted
<b>DOOR WINDOWS</b>	Electric control
<b>STORAGE</b>	Overhead compartments
	Twin cup holders
	Centre console box & storage tray
	Front door pockets
<b>POWER OUTLET</b>	24V cigarette lighter
<b>AIRCONDITIONING</b>	Manual control
<b>INTERIOR LIGHTING</b>	Fluorescent lamp

MYISUZU CO-PILOT AUDIO VISUAL UNIT	
<b>SCREEN TYPE</b>	10.1" 1080p High Definition with capacitive touch
<b>NAVIGATION</b>	Truck tailored GPS based system + live feed traffic alerts and live feed route optimisation via smartphone link (live feed updates are provided for 3 years)
<b>OPERATING SYSTEM</b>	Android Automotive
<b>RADIO</b>	AM/FM/DAB+
<b>INTERNAL STORAGE CAPACITY</b>	32GB
<b>SMARTPHONE INTEGRATION</b>	USB 3.0 socket
	Wi-Fi connectivity
	Android Auto / Apple CarPlay compatible
	Phone storage pocket

DRIVER CONTROLS	
<b>SAFETY SYSTEMS</b>	AEB on/off, DWS on/off/sensitivity adjust, LDW on/off/sensitivity adjust, ESC on/off, HSA on/off/sensitivity adjust
<b>ENGINE</b>	Idle speed control
	Cruise control
	DPD manual regeneration switch
<b>TRANSMISSION (AMT ONLY)</b>	Slow/fast gear engagement control, 1st gear start and normal/economy gear selection modes.
	Gear selection control with R-N-D and sequential shift positions
<b>GENERAL CONTROLS</b>	Headlamp on/off and levelling, windscreen wipers (2 speed and intermittent modes), washers, exhaust brake, turn signals
	PTO engage switch
	Tip body raise and lower lever with safety release mechanism.

INSTRUMENTATION	
<b>MULTI INFORMATION DISPLAY</b>	AEB, FCW, DWS, LDW systems activation alerts
	CTW indicator
	Low engine oil level alert
	Vehicle systems status
	Low fuel level alert
	Fuel consumption information
	Service interval alerts
	Hourmeter
	Adjustable vehicle speed warning
	PTO engaged indicator
<b>GENERAL INSTRUMENTATION</b>	Speedometer & tachometer
	Digital odometer with integrated dual tripmeters
	Engine coolant temperature, fuel level and air pressure gauges

# FRR 110-240 TIPPER

WEIGHTS (kg)							
MODELS	RATINGS*		LOADING LIMIT* (at ground)		WEIGHT #		
	GVM	GCM	FRONT	REAR	FRONT	REAR	TOTAL
<b>FRR 110-240 TIPPER</b>	11,000**	16,000	4,000	7,600	2,530	2,170	4,700
<b>FRR 110-240 AMT TIPPER</b>	11,000**	16,000	4,000	7,600	2,550	2,170	4,720

\* Vehicle ratings and front/rear weight limits are subject to government regulatory requirements and weight distribution analysis. Consult your Isuzu dealer to select the correct vehicle for your specific application.

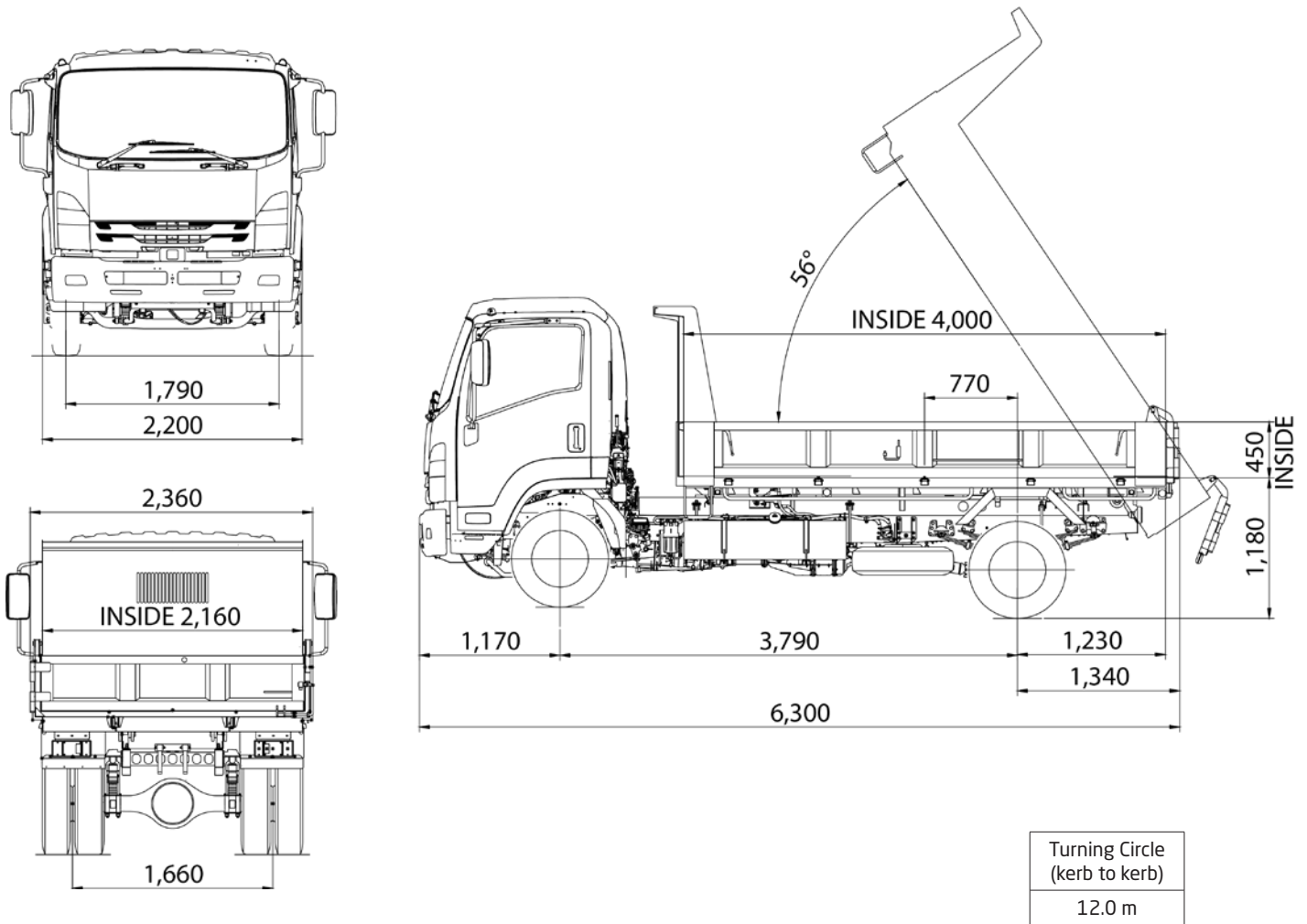

PERFORMANCE (calculated - typical paved road)				
		GEARED SPEED~ (top gear at peak power engine rpm)	LOW SPEED GRADEABILITY (lowest forward gear assuming no wheel slip)	ENGINE SPEED (top gear at 100 km/h)
<b>FRR 110-240</b>	at 11,000 kg GVM	107 km/h @ 2,400 RPM	49%	2,255 RPM

\* Maximum speed achievable depends on vehicle frontal area as well as other factors. Consult your Isuzu dealer for more detailed information.

ORDER CODES	
Models	Codes
<b>FRR 110-240 TIPPER</b>	FH-FRRZD-A22
<b>FRR 110-240 AMT TIPPER</b>	FH-FRRZD-F22

Subject to the conditions outlined in the IAL New Vehicle Warranty, Isuzu F series models carry a standard factory warranty which covers the owner for the first 72 months or 300,000km, no hours stipulation. All Isuzu warranties are subject to mandatory prescribed terms under Australian Consumer Law including consumer guarantees. Harsh Conditions variations to standard factory warranty may apply. For more details visit the Isuzu website at [www.isuzu.com.au](http://www.isuzu.com.au) which explains Isuzu warranties in more detail, or alternatively contact your local Isuzu Truck dealer. All warranties commence from date of initial delivery.

ISUZU AUSTRALIA LIMITED ABN 97 006 962 572 ("IAL"). The information in this spec sheet was correct at time of printing, but all measurements, specifications and equipment are subject to change without notice. Some equipment may have been changed and/or is available at extra cost. IAL may make changes at any time without notice, in prices, colours, materials, equipment and models. IAL makes all reasonable attempts to ensure the availability of all vehicles and equipment. The information in this spec sheet is general in nature. Your Isuzu dealer can confirm all measurements, specifications and vehicle / equipment availability upon request. To the extent permitted by the law, IAL is not liable to any person as result of reliance on the content of this spec sheet.