

FYX 350-350 10X4



WEIGHT RATINGS*

GVM	35,000 kg
GCM	42,500 kg

ENGINE

POWER	257 kW @ 2,000 rpm
TORQUE	1,422 Nm @ 1,400 rpm

TRANSMISSION

6 speed automatic transmission (AT)

* Refer to back page for detailed weight rating information

ISUZU CARE	
WARRANTY	6 Year Standard Warranty
	600,000 km / 10,000 Engine Hours
ROADSIDE ASSIST	6 Year Roadside Support
	24/7 Unlimited km
HARSH APPLICATION WARRANTY (CONCRETE AGITATOR / GARBAGE COMPACTOR)	3 Year Standard Warranty
	300,000 km / no hours stipulation
	3 Year Roadside Support
	24/7 Unlimited km

INTELLIGENT SAFETY	
STANDARD FEATURES	Anti-Lock Braking System (ABS)
	Driver airbag
	Driver seatbelt pretensioner
	Low light capable reversing camera

SERVICE AGREEMENTS			
Optional Service Packages	ESSENTIALS	ESSENTIALS PLUS	TOTAL
SCHEDULED SERVICINGS	●	●	●
CONSUMABLES		●	●
ENGINE, TRANSMISSION & DRIVELINE			●
EXTRAS	After-hours Servicing, Glass, Fuel Card, Pickup - Dropoff		



Subject to the conditions outlined in the IAL New Vehicle Warranty. For further information please visit isuzu.com.au or contact your local dealer.

ENGINE	
DESCRIPTION	Isuzu 6UZ1-TCC
TYPE	6 cylinder 24 valve SOHC
DISPLACEMENT	9,839 cc
COMPRESSION RATIO	17.5:1
BORE X STROKE	120 mm x 145 mm
POWER	257 kW (350PS) @ 2,000 rpm (DIN NET)
TORQUE	1,422 Nm @ 1,400 rpm (DIN NET)
INDUCTION	Electronically controlled variable nozzle turbocharger with air-to-air intercooler
FUEL INJECTION	Direct injection high pressure common rail
EMISSION CONTROL	Cooled EGR with exhaust Diesel Oxidation Catalyst (DOC). ADR 80/03 (Euro V) compliant.

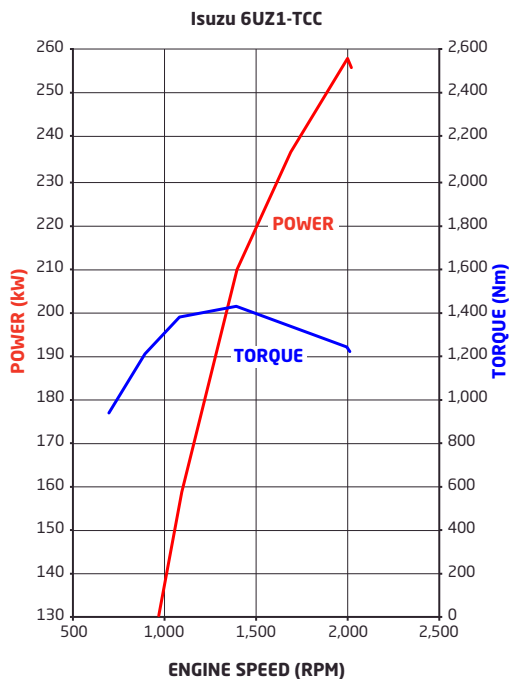

TRANSMISSION	
AT	Description: Allison 4430
	Type: 6 speed automatic
	Ratios:
	1st 2nd 3rd 4th 5th 6th Rev
	4.70 2.21 1.53 1.00 0.76 0.67 5.55
Power Take Off facility: LHS and top openings on transmission bellhousing. Engine driven PTO drive gear.	
Other features: 6th generation electronic controls with adaptive shift. Long life Transynd synthetic fluid.	

AXLES	
FRONT	Description: 2 x Meritor FG941
	Type: Reverse Elliot I-beam
	Capacity: 6,600 kg each
REAR	DESCRIPTION
	Drive axle: Meritor MT-14X
	Tag axle: Hendrickson D22
	TYPE
	Tandem drive axle + tag axle combination
OTHER FEATURES	
Inter-axle lock and cross locks fitted to both axles in tandem drive	
CAPACITY	
Tandem drive: 18,100 kg	
Tag axle: 10,200 kg	
RATIO	
5.286:1	

SUSPENSION	
FRONT	Type: Single stage alloy steel taper leaf springs
	Load sharing: Front suspension load equaliser and shock absorber
REAR	DESCRIPTION
	Drive axle: Hendrickson HAS461
	Tag axle: Hendrickson HLM-2
	TYPE
Airbag	
OTHER FEATURES	
Tag axle automatic raise and lower system	
CAPACITY	
Drive axle: 20,865 kg at ground	
Tag axle: 10,000 kg at ground	

BRAKES	
DESCRIPTION	Meritor 'Q-Plus'
TYPE	Full air 'S-Cam' front and rear drum brakes
DIAMETER X WIDTH FRONT	419 x 152 mm
DIAMETER X WIDTH REAR	419 x 178 mm
PARK BRAKE	Spring park brake acting on all rear wheels
AUXILIARY BRAKE	Air controlled exhaust brake

STEERING	
TYPE	Power assisted recirculating ball
GEAR RATIO	1st axle: 18.8:1
	2nd axle: 22.9:1
TURNS LOCK TO LOCK	3.8
WHEEL LOCK ANGLE	1st axle: 40.0° (inside wheel) / 32.2° (outside wheel)
	2nd axle: 34.0° (inside wheel) / 28.6° (outside wheel)

WHEELS & TYRES	
FRONT	WHEELS
	22.5 x 8.25 ten stud ISO standard Alcoa aluminium wheels
	TYRES
295/80R22.5 152/148M Michelin X Multi Z 2 Tubeless	
REAR	STEER AXLE TYRE RATING
	14,200 kg
	WHEELS
	22.5 x 8.25 ten stud ISO standard Alcoa aluminium wheels
TYRES	Drive axle: 11R22.5 148/145L Michelin X Multi D Tubeless
	Tag axle: 11R22.5 148/145L Michelin X Multi Z Tubeless
DRIVE + TAG AXLE TYRE RATING	34,800 kg
SPARE	Rim supplied

CHASSIS FRAME	
TYPE	Cold rivetted ladder frame.
MATERIAL	HT540A steel members
DIMENSIONS	Side rail (mm): 285 x 85 x 7.0 Rear frame width (mm): 850

FUEL TANK	
TYPE	Frame mounted aluminium fuel tank
CAPACITY	400 L
FUEL CAP	Lockable

ELECTRICAL SYSTEM	
TYPE	24 volt
ALTERNATOR	90 amp
STARTER MOTOR	5.0 kW
BATTERY	2 x 115E41L (651 CCA) batteries connected in series
CAN BUS PROVISION	Underdash CAN system access plug for connection to a Fleet Management System (FMS) (not supplied)

CABIN SPECIFICATIONS & APPOINTMENTS

CABIN GENERAL FEATURES	
ENGINE ACCESS	Electro-hydraulic cab tilt
CAB MOUNTING	Rear coil spring suspension with hydraulic shock absorbers
STEPS	Heavy duty anti-slip steps
DOORS	90° opening internally reinforced front doors
MIRRORS	Heated and powered exterior main mirrors with flat glass and additional independently adjustable convex "spot" mirrors
WIPERS	Two speed windscreen wipers with intermittent wipe mode
EXTERIOR LIGHTING	LED main beam and halogen high beam headlamps. Chrome surround.
	Roof mounted clearance lamps
	Front foglamps
AUDIBLE WARNING	Reverse alarm
GRILLE	Chrome
FRONT BUMPER	Body coloured air dam type
SECURITY	Central locking with remote keyless entry and immobiliser

CABIN INTERIOR	
SEATING	Isri 6860/875 NTS air suspension driver's seat
	Front passenger adjustable bucket seat and front centre seat with folding seat back
SEATBELTS	3-point lap sash seatbelts in all outward seating positions. Driver seatbelt integrated with driver seat. Centre seat lap belts.
STEERING COLUMN	Tilt/telescopic adjustable
ENTRY ASSIST GRIPS	Door and roof pillar mounted
DOOR WINDOWS	Electric control
STORAGE	Overhead compartments
	Twin cup holders
	Centre console box and storage tray
	Passenger glovebox
	Door pockets
POWER OUTLET	24V cigarette lighter
	2.4A high current fast charge USB socket
AIRCONDITIONING	Auto control
INTERIOR LIGHTING	Fluorescent lamp
REAR COMPARTMENT	ADR 42 compliant sleeper with mattress

MYISUZU CO-PILOT AUDIO VISUAL UNIT	
SCREEN TYPE	10.1" 1080p High Definition with capacitive touch
OPERATING SYSTEM	Android Automotive
RADIO	AM/FM/DAB+
INTERNAL STORAGE CAPACITY	32GB
SMARTPHONE INTEGRATION	USB 3.0 socket
	Wi-Fi connectivity
	Android Auto / Apple CarPlay compatible
	Phone storage pocket with wireless charging facility

DRIVER CONTROLS	
ENGINE	Idle speed control
TRANSMISSION	Push button gear selection control
GENERAL CONTROLS	Headlamp on/off and levelling, windscreen wipers (2 speed and intermittent modes), washers, exhaust brake, turn signals
	Inter-axle lock and cross lock engage switches

INSTRUMENTATION	
MULTI INFORMATION DISPLAY	Vehicle systems status
	Low fuel level alert
	Fuel consumption information
	Service interval alerts
	Hourmeter
GENERAL INSTRUMENTATION	Adjustable vehicle speed warning
	Speedometer and tachometer
	Digital odometer with integrated dual tripmeters
	Transmission oil level, oil life, filter life, and condition monitor display
	Engine coolant temperature, fuel level and air pressure gauges



WEIGHTS (kg)							
MODELS	RATINGS*		LOADING LIMIT* (at ground)		CAB CHASSIS WEIGHT #		
	GVM	GCM	FRONT	REAR	FRONT	REAR	TOTAL
FYX 350-350 AUTO	35,000	42,500	12,000	28,100	5,310	3,785	9,095

* Vehicle ratings and front/rear weight limits are subject to government regulatory requirements and weight distribution analysis. Consult your Isuzu dealer to select the correct vehicle for your specific application.

Cab chassis only as supplied and including 10 litres of fuel.

DIMENSIONS (mm)													(m)
MODELS	WB	OAL	FOH	ROH	EA	CE	RT	ORT	CH	FFA (unladen)	RFA (unladen)	RFH (unladen)	TURNING CIRCLE kerb to kerb
FYX 350-350 AUTO	6,425	9,755	1,480	1,850	5,755	7,605	1,840	2,445	3,000	940	1,050	1,050	22.5

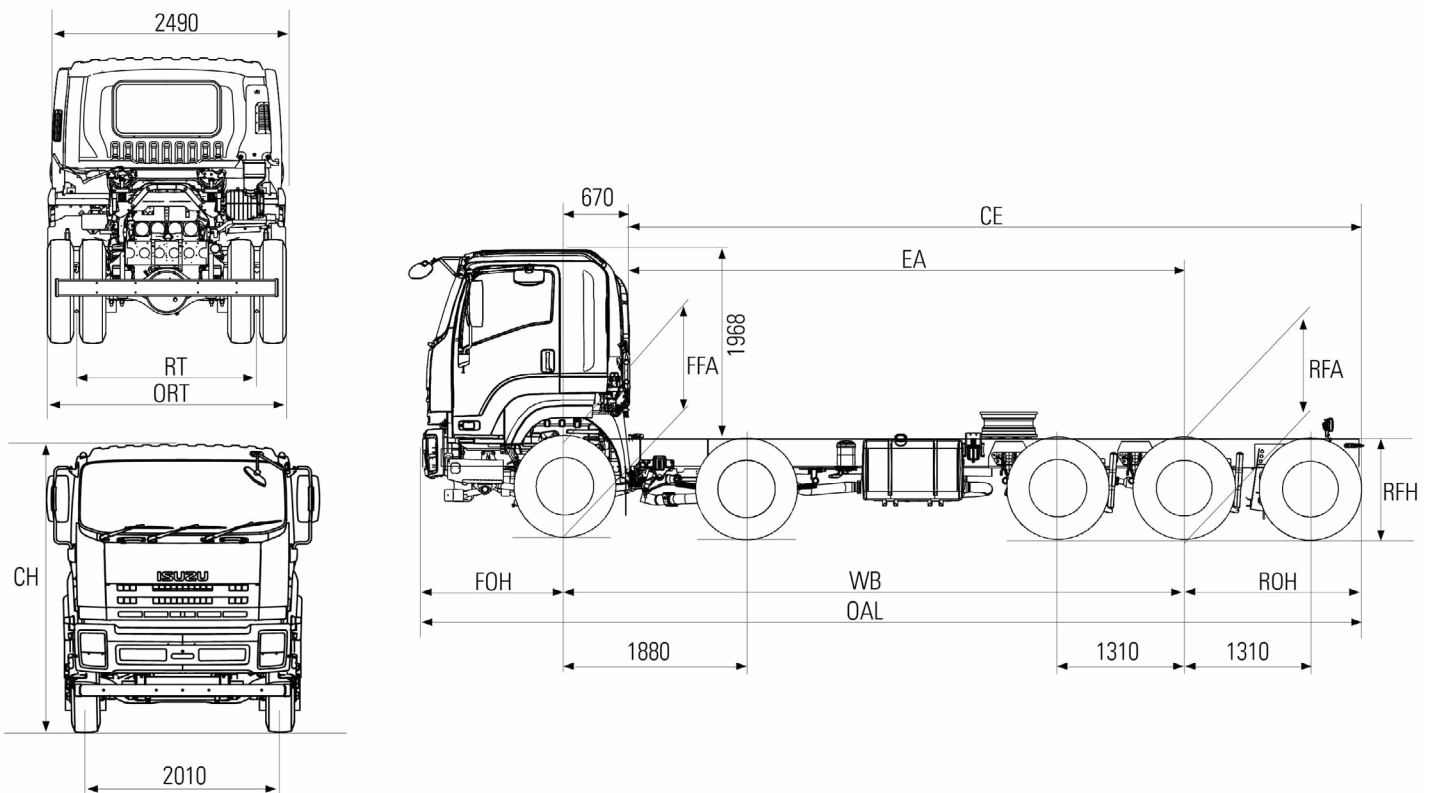

PERFORMANCE (calculated - typical paved road)				
		GEARED SPEED [~] (top gear at peak power engine rpm)	LOW SPEED GRADEABILITY (lowest forward gear assuming no wheel slip)	ENGINE SPEED (top gear at 100 km/h)
FYX 350-350	At 35,000 kg GVM	109 km/h @ 2,000 rpm	41%	1,830 rpm

[~] Maximum speed achievable depends on vehicle frontal area as well as other factors. Consult your Isuzu dealer for more detailed information. Vehicle is speed limited to 100km/h

ORDER CODES	
MODELS	CODES
FYX 350-350 AUTO	FH-FYXJJ-L23

Subject to the conditions outlined in the IAL New Vehicle Warranty, Isuzu FY series models carry a standard factory warranty which covers the owner for the first 72 months or 600,000 kilometres or 10,000 Engine Hours (whichever comes first). All Isuzu warranties are subject to mandatory prescribed terms under Australian Consumer Law including consumer guarantees. Harsh Conditions variations to standard factory warranty may apply. For more details visit the Isuzu website at www.isuzu.com.au which explains Isuzu warranties in more detail, or alternatively contact your local Isuzu Truck dealer. All warranties commence from date of initial delivery.

ISUZU AUSTRALIA LIMITED ABN 97 006 962 572 ("IAL"). The information in this spec sheet was correct at time of printing, but all measurements, specifications and equipment are subject to change without notice. Some equipment may have been changed and/or is available at extra cost. IAL may make changes at any time without notice, in prices, colours, materials, equipment and models. IAL makes all reasonable attempts to ensure the availability of all vehicles and equipment. The information in this spec sheet is general in nature. Your Isuzu dealer can confirm all measurements, specifications and vehicle / equipment availability upon request. To the extent permitted by the law, IAL is not liable to any person as result of reliance on the content of this spec sheet.