

### NPR 75-190

### NPR 75-190 CREW



NPR 75-190 Crew



NPR 75-190

AUSTRALIA'S TOP SELLING TRUCK BRAND SINCE 1989.

#### AT A GLANCE

GVM	7,500 kg
GCM	11,000 kg
Power	140 kW @ 2,600 rpm
Torque	513 Nm @ 1,600 - 2,600 rpm

#### OPTIONS

**Automated Manual Transmission (AMT) model:** includes AMT

**Isuzu Electronic Stability Control (IESC) delete model:** includes AMT / IESC delete

#### ADVANCED TECHNOLOGY

Emissions: Euro V / ADR 80/03

Driver and passenger airbag with seatbelt pretensioner

ECE-R29 compliant cab

Anti-lock Braking System (ABS)

Stability Control System (IESC) - except IESC delete model

Anti Skid Regulator (ASR)

Hill Assist - except with AMT

Electric mirrors

Cruise control

Front and rear stabiliser bars

Driver suspension seat - single cab only

Cornering lamps



# NPR 75-190

## NPR 75-190 CREW

### DRIVELINE AND CHASSIS SPECIFICATIONS

#### ENGINE: ISUZU 4HK1-TCC

- Type:** 4 cylinder 16 valve SOHC  
**Displacement:** 5,193 cc  
**Compression ratio:** 17.5:1  
**Bore x Stroke:** 115 mm x 125 mm  
**Max power (DIN-NET):** 140 kW (188HP) @ 2,600 RPM  
**(JIS Gross):** 145 kW (194HP) @ 2,600 RPM  
**Max torque (DIN-NET):** 513 Nm (378 lb.ft) @ 1,600 - 2,600 RPM  
**(JIS Gross):** 531 Nm (392 lb.ft) @ 1,600 - 2,600 RPM  
**Induction system:** Electronically controlled variable nozzle turbocharger with air-to-air intercooler.  
**Fuel injection:** Direct injection high pressure common rail system.  
**Emission control system:** Cooled EGR with exhaust Diesel Oxidation Catalyst (DOC). ADR 80/03 (Euro V) compliant.

#### CLUTCH

##### Standard model:

- Auto adjusting hydraulic control with vacuum assistance. Single plate 325 mm diameter.
- Total lining area: 966 cm<sup>2</sup>

##### With AMT:

- Fully automated hydraulically controlled wet clutch and fluid coupling with lock up.

#### TRANSMISSION

##### ISUZU MZZ-6F

- PTO provision on LHS of transmission case. PTO drive from counter gear.
  - Gear ratios (: 1)
- | 1st   | 2nd   | 3rd   | 4th   | 5th   | 6th   | Rev   |
|-------|-------|-------|-------|-------|-------|-------|
| 6.369 | 3.767 | 1.966 | 1.355 | 1.000 | 0.782 | 6.369 |

##### Standard model:

- 6 speed manual. Synchromesh on gears 1-6.

##### With AMT:

- 6 speed Automated Manual Transmission (AMT) with both fully automatic and clutchless manual operation modes.

#### AXLES

##### Front: Isuzu F031

- Reverse Elliot I-beam. 3,100 kg capacity.

##### Rear: Isuzu R066

- Full floating Banjo type. Four differential pinions. 6,600 kg capacity.
- Drive ratio: 3.909:1 (Standard model), 4.100:1 (with AMT)

#### SUSPENSION

##### Front:

- **Single cab:** Single stage allow steel taper-leaf springs.
- **Crew cab:** Single stage alloy steel multi-leaf springs.
- Double acting hydraulic shock absorbers. Stabiliser bar.

##### Rear:

- Multi-leaf main spring, multi-Leaf helper spring.
- Double acting hydraulic shock absorbers. Stabiliser bar

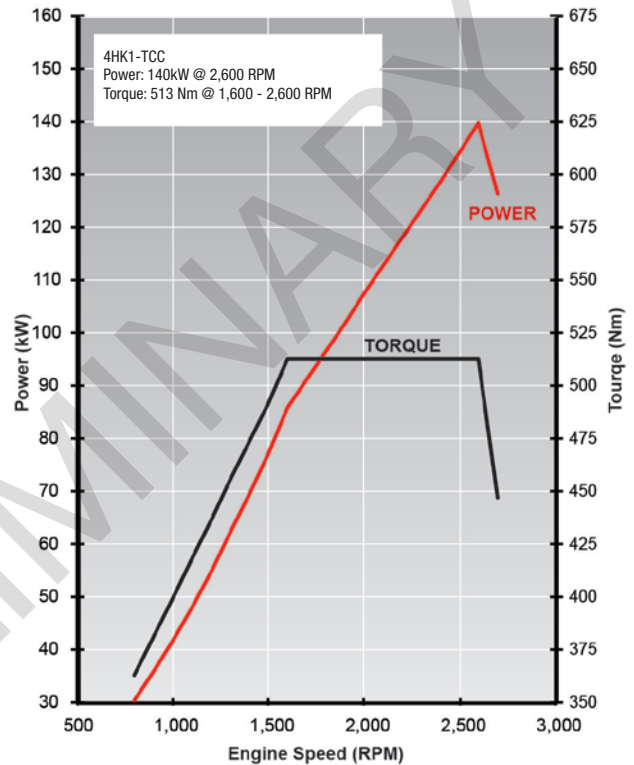

#### BRAKES

- Auto adjusting front and rear disc brakes with dual circuit hydraulic control, integrated boost assist and electronic brake force distribution (EBD).
- ABS, ASR traction control, IESC stability control - except IESC delete model.
- Hill Assist - except with AMT.
- Front disc diameter: 310 mm
- Rear disc diameter: 310 mm
- 203 mm diameter drum park brake mounted on rear of transmission.
- Vacuum controlled exhaust brake.

#### STEERING

- Power assisted recirculating ball steering.
- Gear ratio: 20.9:1
- Turns lock to lock: 5.4
- Maximum angle: 43° (inside wheel) / 33° (outside wheel)

#### WHEELS AND TYRES

- 17.5 x 6.00 six stud steel wheels.
- 205/75R 17.5 124/122M Michelin X Multi Z Tubeless.
- Maximum tyre rating:
  - Steer axle: 3,200 kg
  - Drive axle: 6,000 kg
- 1 frame mounted spare wheel and tyre assembly.

#### CHASSIS FRAME

- Cold rivetted ladder frame. SAPH440 weldable steel sidemembers. Parallel side rails and rivetless top flange.
- Frame dimensions:
  - Side rail (mm): 216 x 70 x 6.0
  - Rear frame width (mm): 850

## FUEL TANK

- Frame mounted 140L steel fuel tank.
- Lockable fuel cap.

## ELECTRICAL SYSTEM

- 24 volt electrical system.
- 90 amp alternator.
- 4.5 kW starter motor.
- 2 x 80D26L (630 CCA) batteries connected in series.

## CABIN SPECIFICATIONS AND APPOINTMENTS

### CAB EXTERIOR

- All steel construction. High tensile steel used for cab underframe. **Single cab:** Manual cab tilt to 45° with torsion bar assistance.
- Complies with ECE-R29 cab strength standard.
- **Single cab:** Liquid filled front and rear cab mounts. **Crew cab:** Rubber cab mounts.
- Heavy duty non slip entry steps.
- 90° opening internally reinforced front doors.
- Water spray suppression guards and front mudflaps.
- Laminated windscreen with shade band.
- Two speed windscreen wipers with intermittent wipe mode.
- Halogen multi-reflector headlamps incorporating turn signals. Additional door mounted integrated side indicator/cornering lamps.
- Combination brake, turn, reverse and marker lamps, registration plate illumination lamps. Extended wiring harness. Reverse alarm.
- Roof-mounted clearance lamps.
- Heated and powered exterior main mirrors with flat glass and additional independently adjustable convex “spot” mirrors.
- Chrome grille.
- Body coloured impact resisting polycarbonate bumper with steel backing frame. Includes front foglamps.

### CAB INTERIOR

- Contoured adjustable driver's bucket seat. **Single cab:** includes mechanical suspension rated to 130 kg.
- Front passenger bench seat with 2 seat capacity.
- **Crew cab:** Engine access provided under removable driver seat base and tiltable front passenger seat.
- **Crew cab:** Rear bench seat with 4 seat capacity.
- 3-point lap sash seatbelts in all outboard seating positions. Driver and outboard front passenger seatbelts fitted with pretensioner. Centre seat lap belts.
- Driver and outboard front passenger airbag.
- **With AMT:** Driver's footrest.
- Door and roof pillar entry assist grips. **Crew cab:** Full width rear grab rail with ashtray.
- Full interior trim, padded roof lining and vinyl floor covering. Driver and passenger windscreen header storage shelf.
- Tilt/Telescopic adjustable steering column, soft feel urethane steering wheel.
- Electric windows.
- Central locking with remote keyless entry and immobiliser.
- Twin cup holders. 24V cigarette lighter. Dashboard hook.
- Front door mounted storage pockets and driver's side ashtray.
- Centre console box with storage tray. Fold down storage tray behind centre seat backrest.
- Fully integrated auto control air conditioning and heater/demister with 4-speed fan and outlets for windscreen, side windows, face and floor.
- Interior lamp with On/Door/Off switch. **Single cab:** fluorescent type. **Crew cab:** standard type.
- 2 DIN, two speaker multimedia unit with 6.2" LCD capacitive touch screen. 1.6GHz processor with Android operating system. DAB+ digital radio and fully integrated Bluetooth with voice recognition. Inbuilt PDF, photo and movie viewer. Internet radio accessible via smartphone. 32GB internal file storage. USB and auxilliary input connection provisions.

- DIN sized compartment for storage or for CB radio installation.

### DRIVER CONTROLS

- Key-operated engine start/stop and steering lock. Engine idle speed control.
- Hill Assist slow/fast engagement control and on/off switch - except with AMT.
- ASR and IESC on/off (except delete IESC model). ASR on/off (delete IESC model).
- **With AMT:** AMT slow/fast gear engagement control, 1st gear start and normal/economy gear selection modes.
- **With AMT:** Gear selection control with R-N-D and sequential shift positions.
- **Left side combination stalk:** Windscreen wipers, washers and exhaust brake.
- **Right side combination stalk:** Turn signals, headlamps, cruise control.

### INSTRUMENTATION

- Electronically driven speedometer and tachometer. Digital odometer with integrated dual tripmeter. Engine coolant temperature and fuel level gauges.
- **Warning lamps:** Check engine, oil pressure, ABS, SRS airbag, alternator charge, service brakes, park brake, seat belt unfastened, low fuel level. **With AMT:** Check AMT.
- **Indicator lamps:** Hill Assist (except with AMT), warm up system, high beam, ASR, IESC (except delete IESC model), exhaust brake, turn signals, cruise control. **With AMT:** Econo-mode, 1st gear start.
- **With AMT:** Gear selection display.
- **Multi information display:** Shows service interval, instantaneous and average fuel consumption, hourmeter, voltmeter, time/day/date and includes 40-120km/h adjustable vehicle speed warning.

### OPTIONS AND GENUINE ACCESSORIES

Include the following (extra cost, request a brochure and further details from your Isuzu dealer):

#### Multimedia unit:

- Telematics system.
- Isuzu satellite navigation including 3 years of free updates.
- Supports up to five camera inputs. One digital camera with infra red and rear microphone input active when reversing, Four analogue cameras.
- Reversing sensors.
- Tyre pressure monitoring system.
- Blind spot viewing cameras.
- ADAS (Advanced Driver Assistance System). Includes lane departure warning, forward collision warning and pedestrian collision alert.
- Wireless inductive phone charger.

#### Other:

- Airbag compatible bullbar.
- 3,500 kg rated towbar.
- Air deflector.

## ISUZU CARE

Isuzu Care gives truck owners access to products and services including Roadside Assist, Service Agreements, Extended Care, Extended Isuzu Assist and the Isuzu Care Centre. Call 1800 035 640.

### WEIGHTS (kg)

Models	Ratings*		Loading Limit* (at ground)		Cab Chassis Weight #		
	GVM	GCM	Front	Rear	Front	Rear	Total
NPR 75-190 MWB	7,500	11,000	3,100	6,000	1,800	890	2,690
NPR 75-190 AMT MWB	7,500	11,000	3,100	6,000	1,800	890	2,690
NPR 75-190 AMT MLWB	7,500	11,000	3,100	6,000	TBC	TBC	TBC
NPR 75-190 LWB	7,500	11,000	3,100	6,000	1,820	910	2,730
NPR 75-190 AMT LWB	7,500	11,000	3,100	6,000	1,820	910	2,730
NPR 75-190 CREW	7,500	11,000	3,100	6,000	2,010	965	2,975
NPR 75-190 AMT CREW	7,500	11,000	3,100	6,000	2,010	965	2,975

\* Vehicle ratings and front/rear weight limits are subject to government regulatory requirements and weight distribution analysis. Consult your Isuzu dealer to select the correct vehicle for your specific application. # Cab chassis only as supplied and including 10 litres of fuel.

### DIMENSIONS (mm)

Models	WB	OAL	FOH	ROH	EA	CE	RT	ORT	CH	FFA (unladen)	RFA (unladen)	RFH (unladen)	Turn Circle (m)
													KERB TO KERB
NPR 75-190 MWB	3,365	5,985	1,110	1,510	2,680	4,302	1,650	2,115	2,270	675	790	830	12.4
NPR 75-190 MLWB	3,815	6,630	1,110	1,705	3,130	4,947	1,650	2,115	2,270	TBC	TBC	TBC	14.0
NPR 75-190 LWB	4,175	7,338	1,110	2,053	3,490	5,655	1,650	2,115	2,270	675	790	845	15.3
NPR 75-190 CREW	4,175	7,338	1,110	2,053	2,510	4,654	1,650	2,115	2,270	660	800	860	15.3

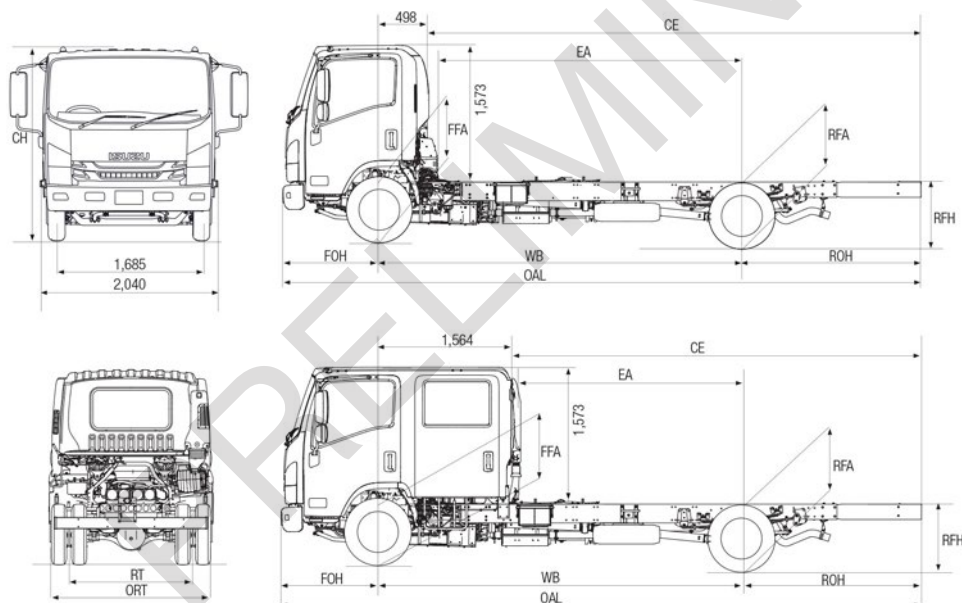

### PERFORMANCE (calculated - typical paved road)

		Geared Speed* (top gear at peak power engine RPM)	Low Speed Gradeability (lowest forward gear assuming no wheel slip)	Engine Speed (top gear at 100km/h)
NPR 75-190	At 7,500 kg GVM	118 km/h @ 2,600 RPM	42%	2,195 RPM
NPR 75-190 AMT	At 7,500 kg GVM	113 km/h @ 2,600 RPM	44%	2,305 RPM

\*Maximum speed achievable depends on vehicle frontal area as well as other factors. Consult your Isuzu dealer for more detailed information.

### ISUZU WARRANTIES

STANDARD <sup>1</sup>	
New Vehicle	3 years • 100,000km • 2,000 hours
Cab Perforation Corrosion	3 years • unlimited km
Isuzu Assist: 24 hour roadside assistance (3 years, unlimited km)*	
EXTENDED CARE <sup>2</sup>	
Extended Warranty: 5 years • 250,000km • 4,500 hours	
Isuzu Assist: 24 hour roadside assistance (5 years, unlimited km)	

### ORDER CODES

Model	Code	Model	Code
NPR 75-190 MWB	NH-NPRAC-H18	NPR 75-190 AMT LWB	NH-NPRAC-N18
NPR 75-190 AMT MWB	NH-NPRAC-J18	NPR 75-190 AMT LWB (NO IESC)	NH-NPRAC-T18
NPR 75-190 AMT MLWB	NH-NPRAC-K18	NPR 75-190 CREW	NH-NPRCC-M18
NPR 75-190 LWB	NH-NPRAC-M18	NPR 75-190 AMT CREW	NH-NPRCC-N18

<sup>1</sup> Subject to the conditions outlined in the IAL New Vehicle Warranty, the Isuzu NPR models carry a standard factory warranty which covers the owner: (i) for the entire vehicle, for the first 36 months or 100,000 km or 2,000 hrs (whichever comes first), (ii) against cab perforation corrosion, for 36 months and unlimited kilometres. <sup>2</sup> Extended Warranty as illustrated may be purchased to cover the owner against the failure of original components, but may exclude some components and expendable items such as oil, filters, etc. \*Valid for three years from the date of new vehicle purchases. All Isuzu warranties are subject to mandatory prescribed terms under Australian Consumer Law including customer guarantees. For more details visit the Isuzu website which explains Isuzu warranties in more detail, or alternatively contact your local dealer. All warranties commence from date of delivery.

ISUZU AUSTRALIA LIMITED ABN 97 006 962 572 ("IAL"). The information in this spec sheet was correct at time of printing, but all measurements, specifications and equipment are subject to change without notice. Some equipment may have been changed and/or is available at extra cost. IAL may make changes at any time without notice, in prices, colours, materials, equipment and models. IAL makes all reasonable attempts to ensure the availability of all vehicles and equipment. The information in this spec sheet is general in nature. Your Isuzu dealer can confirm all measurements, specifications and vehicle / equipment availability upon request. To the extent permitted by the law, IAL is not liable to any person as result of reliance on the content of this spec sheet.