

REVISION HISTORY				
ZONE	REV	DESCRIPTION	DATE	APPROVED

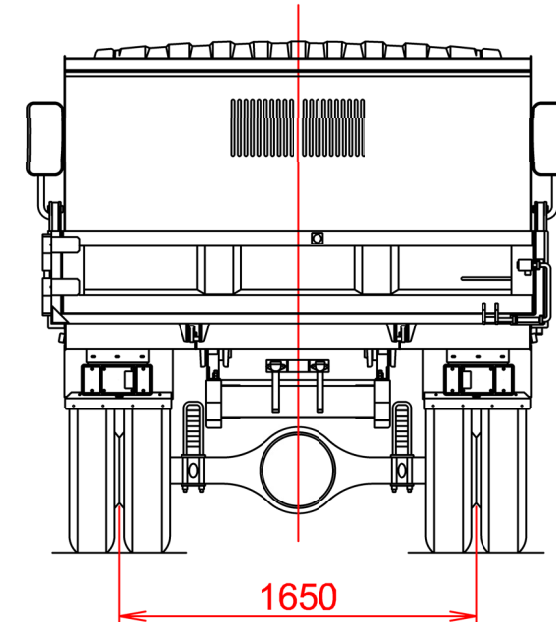
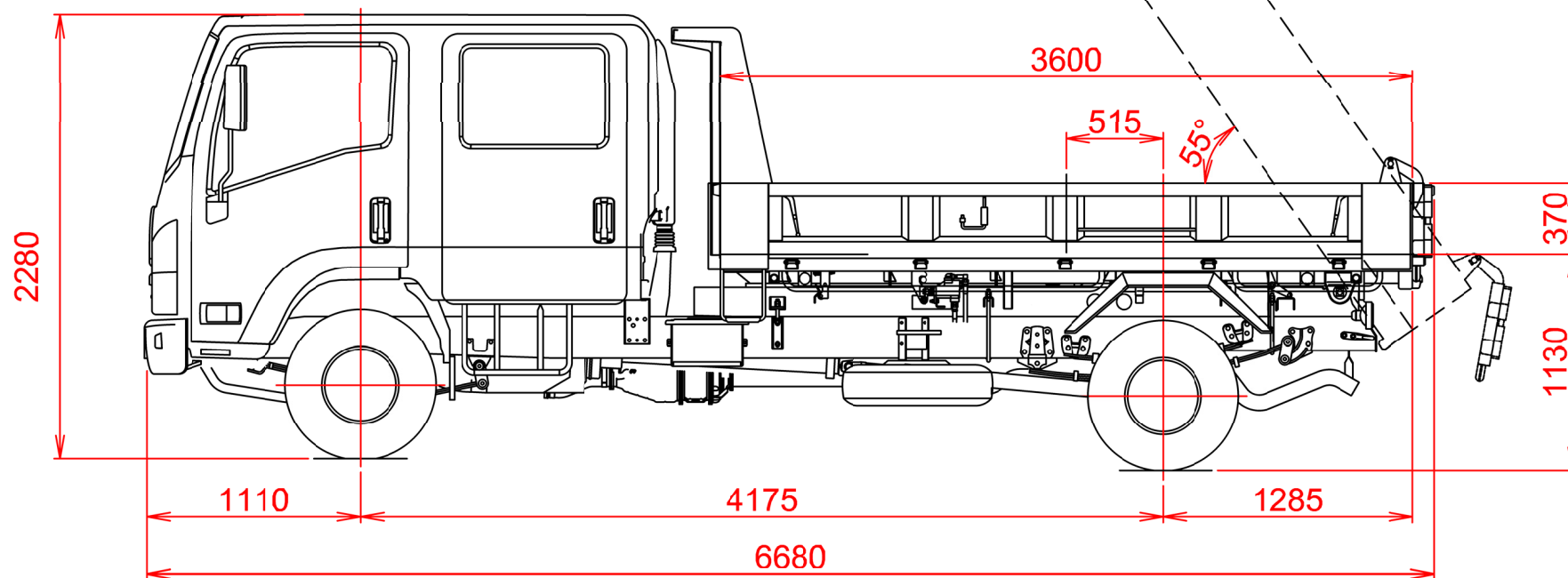
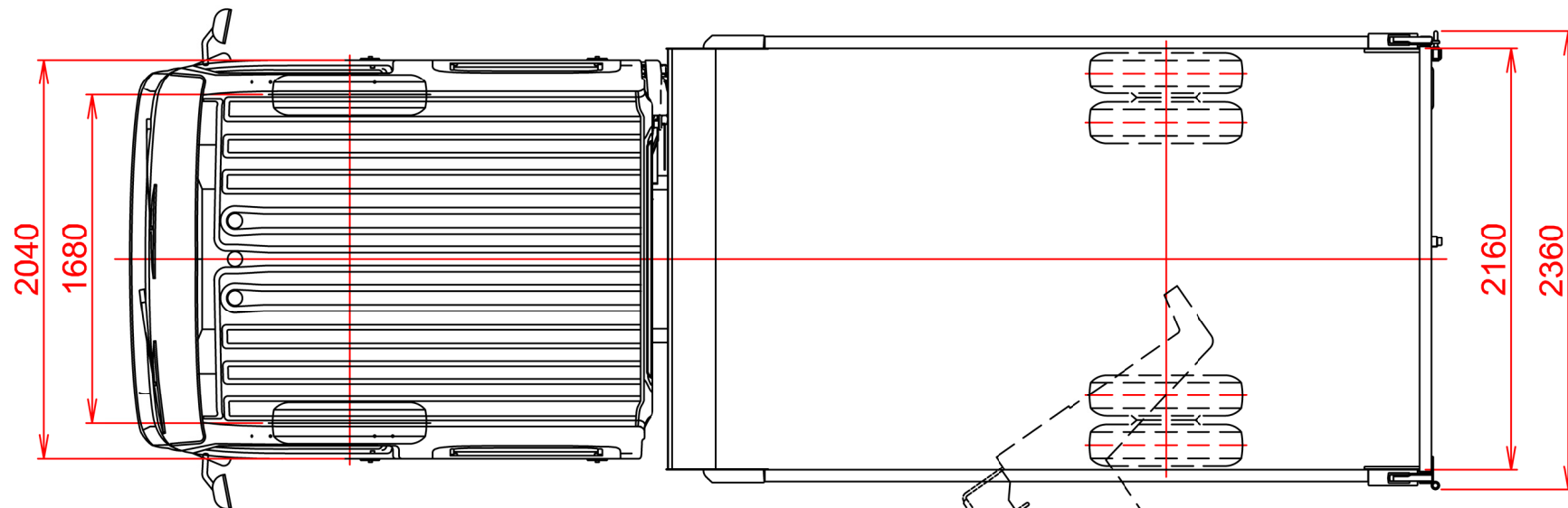

BODY BUILDERS NOTES	
1.	DIMENSIONS ARE SHOWN FOR INDICATIVE PURPOSES ONLY
2.	REFER TO THE VEHICLE FOR ACTUAL MEASUREMENTS

UNLESS OTHERWISE SPECIFIED  
DIMENSIONS ARE IN MILLIMETERS.  
TOLERANCES ARE:  
DECIMALS ANGLES  
.X +/- 0.8 +/- 2 DEGREES  
.XX +/- 0.25

DO NOT SCALE DRAWING  
THIRD ANGLE PROJECTION

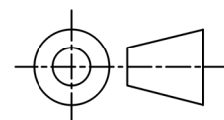

CONTRACT NO.

APPROVALS	DATE
DRAWN N SALLEN	04/09/15
CHECKED S HUMPHRIES	04/09/15
ENGR N SALLEN	04/09/15
DESIGN ACTIVITY	BBG

**ISUZU**  
ISUZU AUSTRALIA LIMITED

TITLE

**MY15.5 NPR 65/45-190 CREW TIPPER**

SIZE

A3

CAGE CODE

N/A

DWG NO.

NH-MY15.5-NPR 65/45-190 CREW TIPPER

REV.

A

SCALE NOT TO SCALE

CALC.WT

ACT.WT

SHEET 1 OF 1