

REVISION HISTORY				
ZONE	REV	DESCRIPTION	DATE	APPROVED

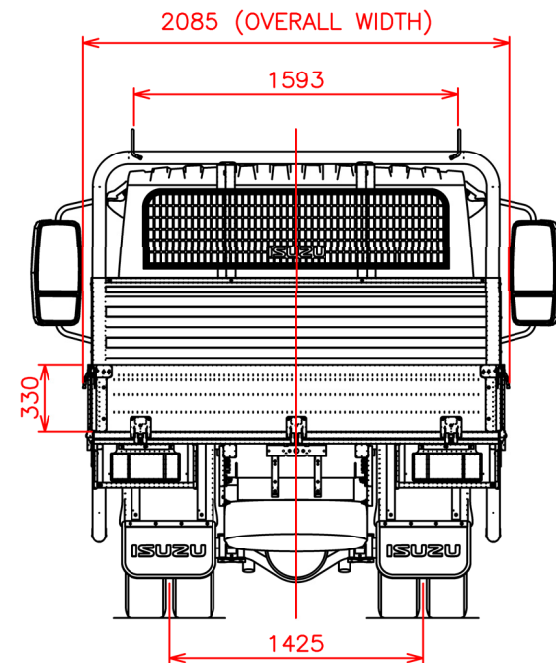
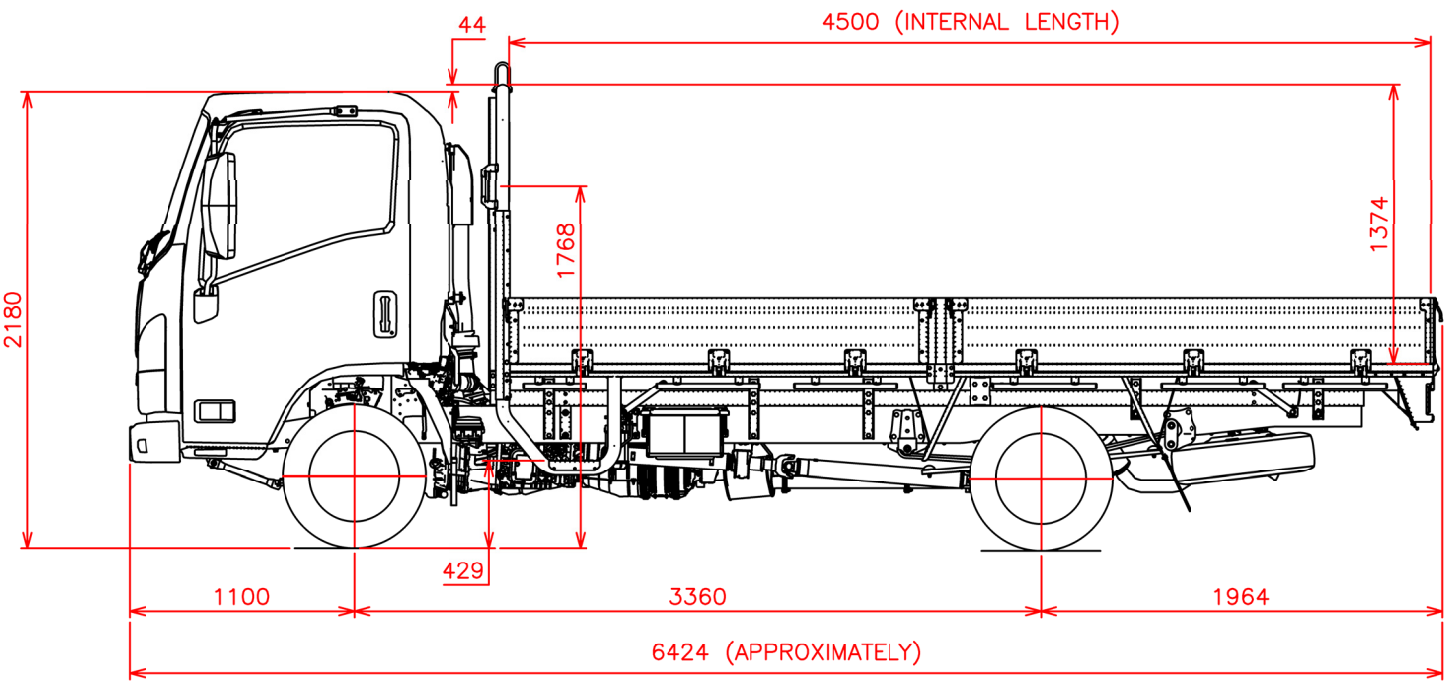
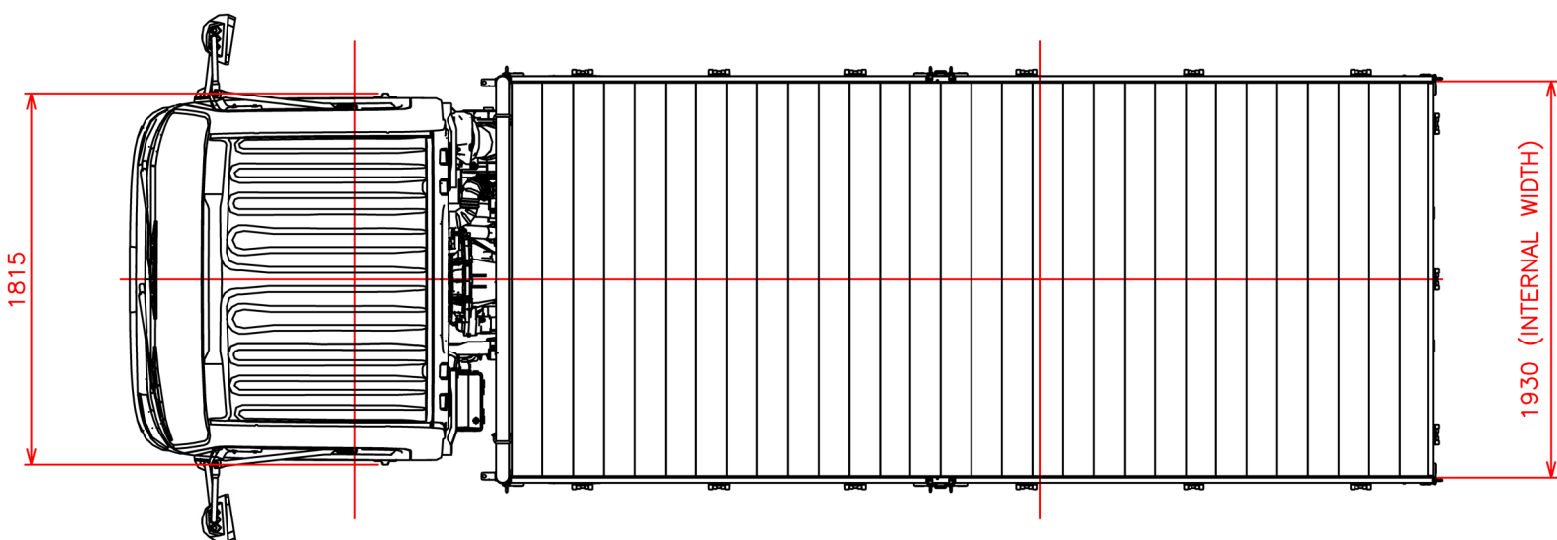

BODY BUILDERS NOTES

1. DIMENSIONS ARE SHOWN FOR INDICATIVE PURPOSES ONLY
2. REFER TO THE ACTUAL VEHICLE FOR MEASUREMENTS

UNLESS OTHERWISE SPECIFIED
DIMENSIONS ARE IN MILLIMETERS.
TOLERANCES ARE:
DECIMALS ANGLES
.X +/- 0.8 +/- 2 DEGREES
.XX +/- 0.25
DO NOT SCALE DRAWING
THIRD ANGLE PROJECTION

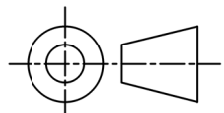

CONTRACT NO.	
APPROVALS	DATE
DRAWN N SALLEN	26/08/15
CHECKED S HUMPHRIES	26/08/15
ENGR N SALLEN	26/08/15
DESIGN ACTIVITY	BBG

ISUZU
ISUZU AUSTRALIA LIMITED

TITLE
MY15.5 NLR 45-150 MWB TRAYPACK

SIZE A3	CAGE CODE N/A	DWG NO. NH-MY15.5-NLR 45-150 MWB TRAYPACK	REV. A
SCALE NOT TO SCALE	CALC.WT	ACT.WT	SHEET 1 OF 1