

REVISION HISTORY

ZONE	REV	DESCRIPTION	DATE	APPROVED

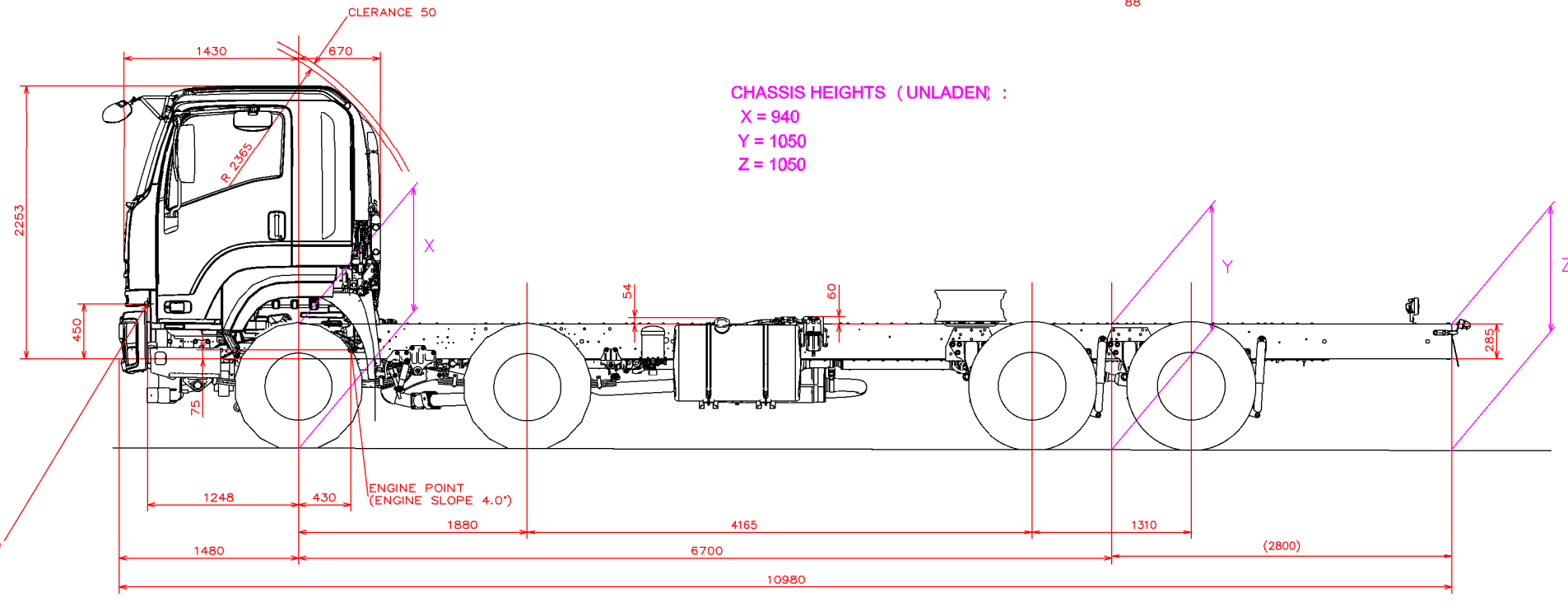
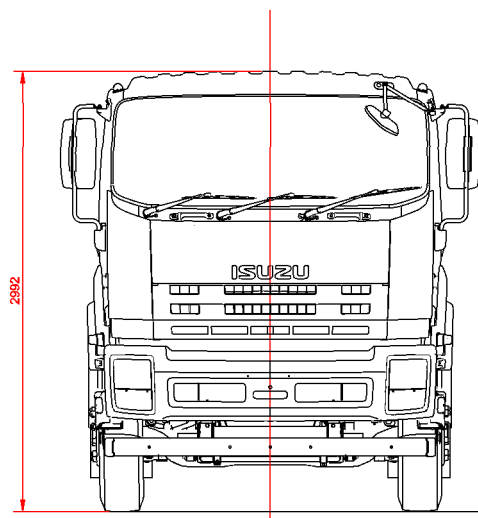
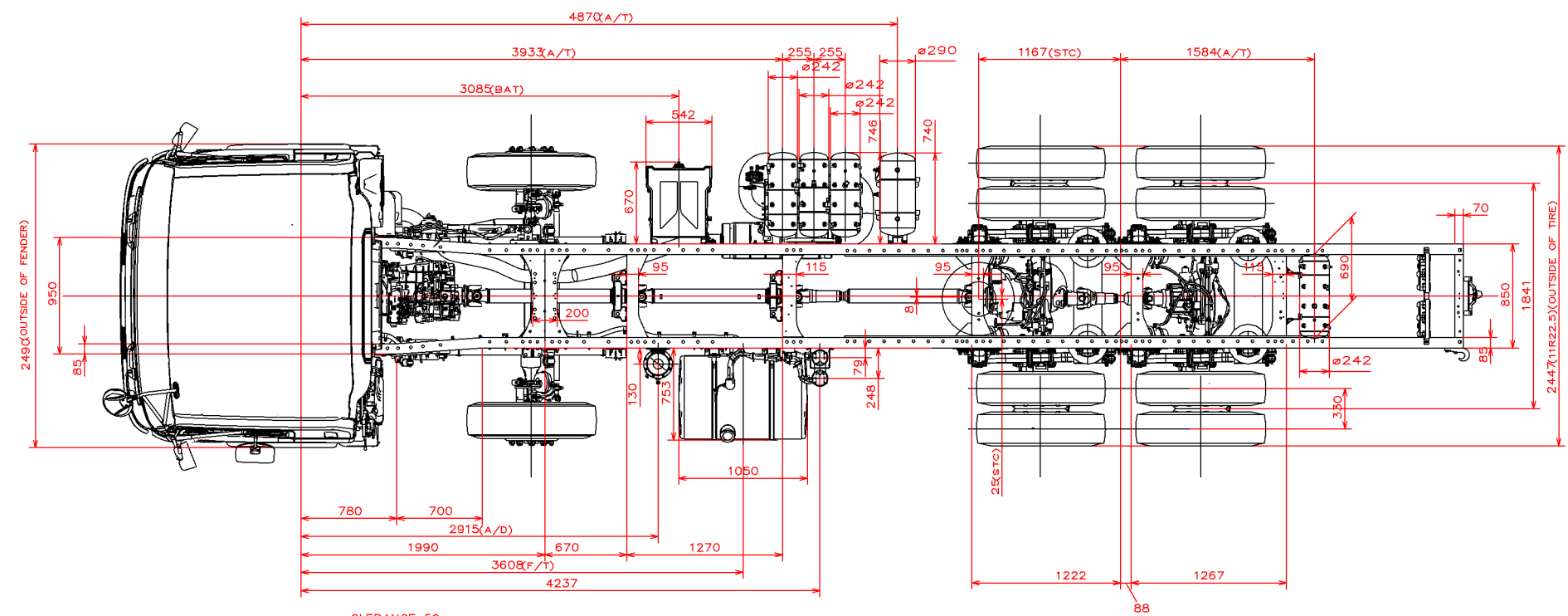

CHASSIS HEIGHTS (UNLADEN) :  
 X = 940  
 Y = 1050  
 Z = 1050

BODY BUILDERS NOTES

- DIMENSIONS ARE SHOWN FOR INDICATIVE PURPOSES ONLY
- REFER TO THE VEHICLE FOR ACTUAL DIMENSIONS

UNLESS OTHERWISE SPECIFIED  
 DIMENSIONS ARE IN MILLIMETERS.  
 TOLERANCES ARE:  
 DECIMALS ANGLES  
 X +/- 0.8 +/- 2 DEGREES  
 XX +/- 0.25  
 DO NOT SCALE DRAWING  
 THIRD ANGLE PROJECTION

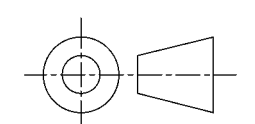

CONTRACT NO.  
 FH-FYH-JJ-E13 / FYH77VU-WDSH

APPROVALS	DATE
DRAWN <b>N SALLEN</b>	10/07/13
CHECKED <b>C WHITE</b>	10/07/13
ENGR <b>N SALLEN</b>	10/07/13
DESIGN ACTIVITY <b>BBG</b>	

**ISUZU**  
 ISUZU AUSTRALIA LIMITED

TITLE  
**MY13 FYJ 2000 X LONG**

SIZE <b>A3</b>	CAGE CODE <b>N/A</b>	DWG NO. <b>FH-MY13-FYJ2000XLONG</b>	REV. <b>ONE</b>
----------------	----------------------	-------------------------------------	-----------------