

REVISION HISTORY

ZONE	REV	DESCRIPTION	DATE	APPROVED

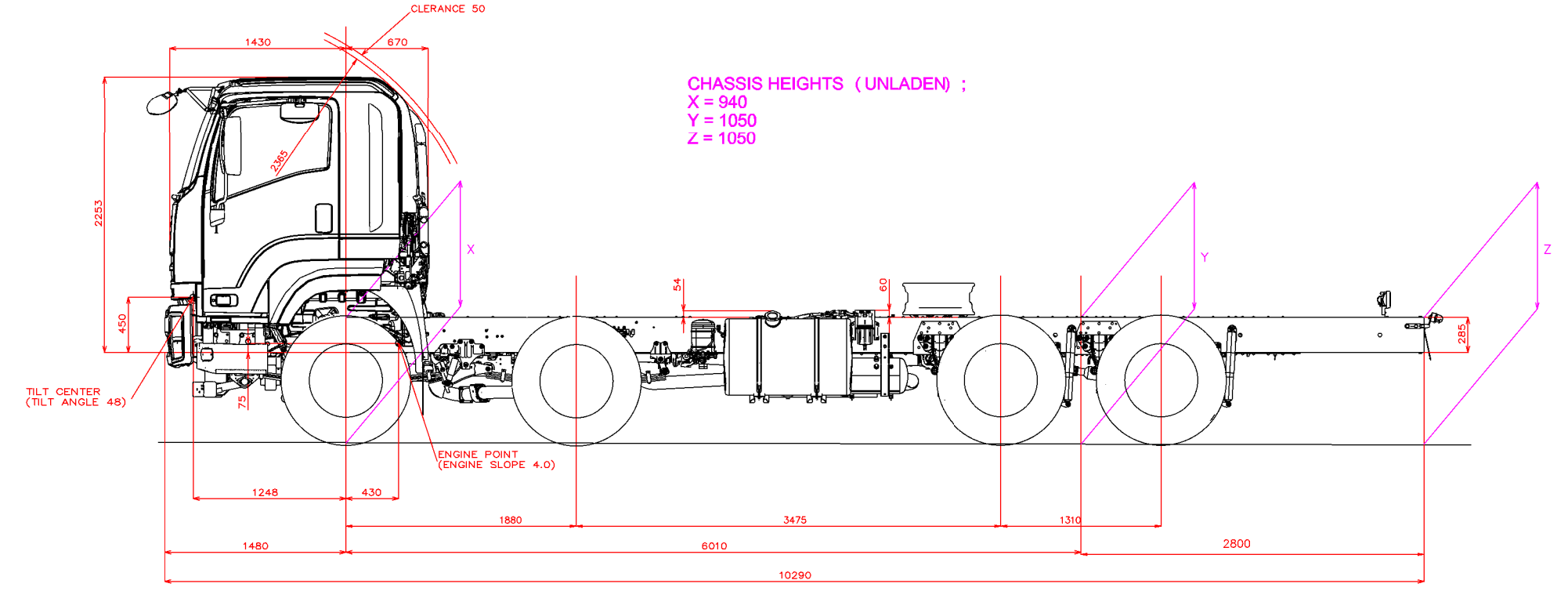
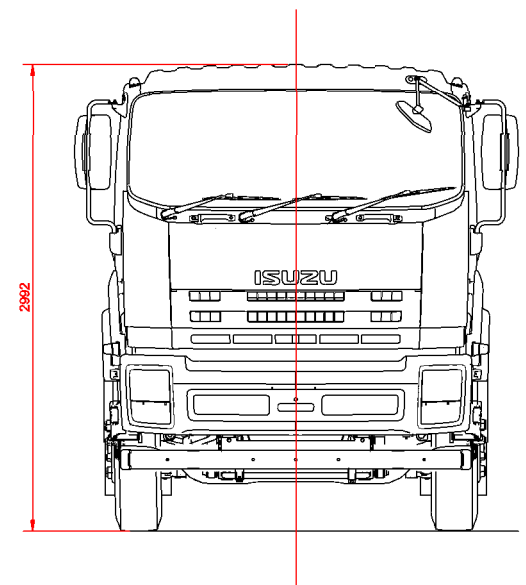
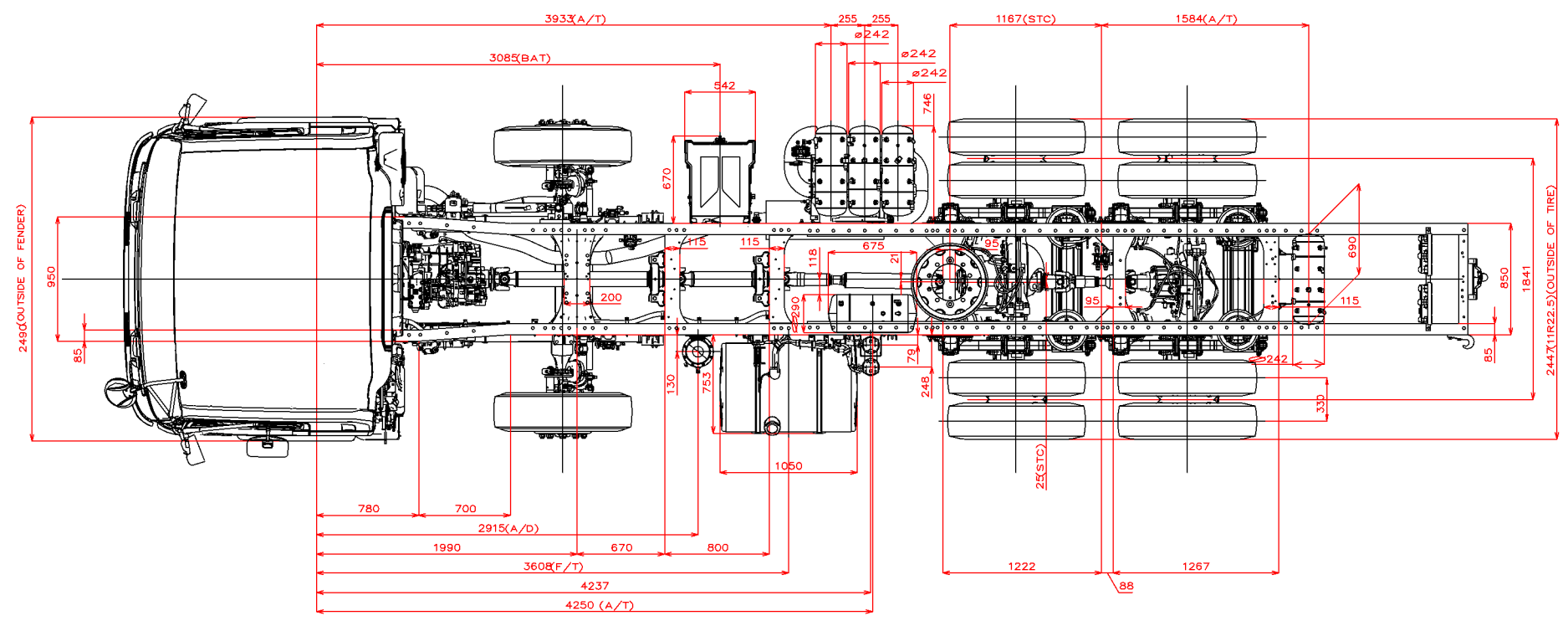

CHASSIS HEIGHTS (UNLADEN) ;
 X = 940
 Y = 1050
 Z = 1050

BODY BUILDERS NOTES	
1.	DIMENSIONS ARE SHOWN FOR INDICATION ONLY
2.	REFER TO VEHICLE FOR ACTUAL MEASUREMENTS

UNLESS OTHERWISE SPECIFIED
 DIMENSIONS ARE IN MILLIMETERS.
 TOLERANCES ARE:
 DECIMALS ANGLES
 X +/- 0.8 +/- 2 DEGREES
 XX +/- 0.25
 DO NOT SCALE DRAWING
 THIRD ANGLE PROJECTION

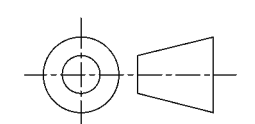

CONTRACT NO.
 FH-FYH-JJ-D13 / FYH77VU-UDSH

APPROVALS	DATE
DRAWN N SALLEN	09/07/13
CHECKED C WHITE	09/07/13
ENGR N SALLEN	09/07/13
DESIGN ACTIVITY BBG	

ISUZU
 ISUZU AUSTRALIA LIMITED

TITLE
MY 13 FYJ 2000 LONG

SIZE A3	CAGE CODE N/A	DWG NO. FH-MY13-FYH2000LONG	REV. ONE
----------------	----------------------	------------------------------------	-----------------